



IMAGE: A MAP OF THE STARS OF THE ORION CONSTELLATION

Print ISSN: 2631-8474 Online ISSN: 2631-8482

# JournalPreview

London Journal of Engineering Research

Volume 22 | Issue 4 | Compilation 1.0



# JournalPreview

LONDON JOURNAL ENGINEERING RESEARCH

This document is a pre-published view of London Journal of Engineering Research Volume 22, Issue 4 and Compilation 1.0. For any minor changes and updations kindly follow your paper's live editing URL given in sent email or get in touch with our support team at [support@journalspress.com](mailto:support@journalspress.com) or visit our website to use live chat support. This is a beta document thus order, content or existence of papers may alter in the published eJournal. You are requested to kindly acknowledge and approve your research paper in this JournalPreview within three days.

# Journal Content

In this Issue



London  
Journals Press

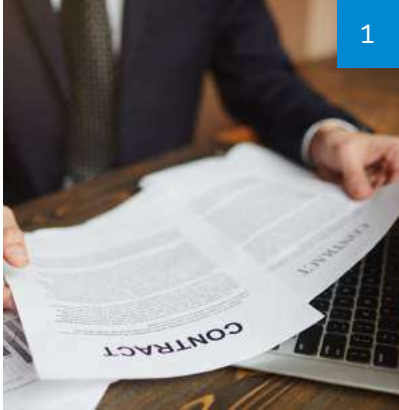

1

- i. Journal introduction and copyrights
  - ii. Featured blogs and online content
  - iii. Journal content
  - iv. Editorial Board Members
- 



5

1. Contract Financing on Construction Cost...  
**pg. 1-4**
  2. Negotiation Strategies on Construction Cost...  
**pg. 5-15**
  3. The Manufacturing Method of the Field Driven...  
**pg. 17-25**
  4. Simulation Analysis and Research on the...  
**pg. 27-32**
  5. Psychoanalytic View of Neurotic Forms of...  
**pg. 33-37**
- 

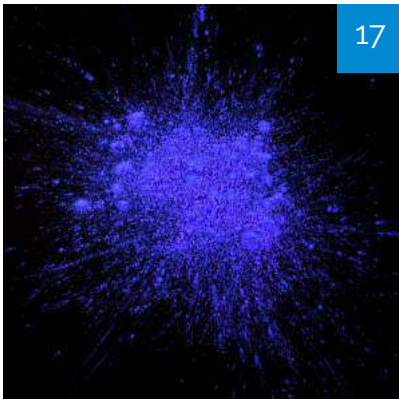

17

- v. London Journals Press Memberships



Scan to know paper details and  
author's profile

# Contract Financing on Construction Cost Overruns in Real Estate Projects: Nairobi and Kisumu Counties, Kenya

*Joanne A. Kepher, Prof. Raphael O. Nyonje & Prof. Charles M. Rambo*

*University of Nairobi*

## ABSTRACT

Cost overruns have provided a significant challenge in the construction industries of both developed and developing countries. Financial and Contract Management incorporate designs and approaches which take keen interest on issues associated with Contract Financing which informed the basis of investigation of the concept of Construction Cost Overruns in Real Estate Projects in this study. The purpose of this study was to investigate the influence of Contract Financing on Construction Cost Overruns of real estate projects in Nairobi and Kisumu Counties. The study was guided by objectives to establish the extent to which Contract Financing influence construction cost overruns in real estate projects.

*Keywords:* contract financing, construction cost overrun, real estate projects.

*Classification:* DDC Code: 658.1511 LCC Code: HF5657.4

*Language:* English



LJP Copyright ID: 392951

Print ISSN: 2631-8474

Online ISSN: 2631-8482

London Journal of Engineering Research

Volume 22 | Issue 4 | Compilation 1.0



© 2022. Joanne A. Kepher, Prof. Raphael O. Nyonje & Prof. Charles M. Rambo. This is a research/review paper, distributed under the terms of the Creative Commons Attribution-Noncommercial 4.0 Unported License <http://creativecommons.org/licenses/by-nc/4.0/>, permitting all noncommercial use, distribution, and reproduction in any medium, provided the original work is properly cited.



# Contract Financing on Construction Cost Overruns in Real Estate Projects: Nairobi and Kisumu Counties, Kenya

Joanne A. Kepher<sup>α</sup>, Prof. Raphael O. Nyonje<sup>σ</sup> & Prof. Charles M. Rambo<sup>ρ</sup>

## ABSTRACT

*Cost overruns have provided a significant challenge in the construction industries of both developed and developing countries. Financial and Contract Management incorporate designs and approaches which take keen interest on issues associated with Contract Financing which informed the basis of investigation of the concept of Construction Cost Overruns in Real Estate Projects in this study. The purpose of this study was to investigate the influence of Contract Financing on Construction Cost Overruns of real estate projects in Nairobi and Kisumu Counties. The study was guided by objectives to establish the extent to which Contract Financing influence construction cost overruns in real estate projects. The study was based on a pragmatic paradigm which provides for the use of both qualitative and quantitative research methodologies. The research adopted descriptive survey and correlational research designs. The study targeted a population of 4000 project professionals that are 7 from active real estates in Nairobi and Kisumu Counties and 10 key informants from the real estate industry. Using the Krejcie and Morgan table of sampling method, the sample size for this study was 351. The study then adopted stratified, simple random and purposive sampling methods to select appropriate sample sizes from the study population. Structured questionnaire was the main instrument for data collection, supported by the interview guide. Hypothesis tested at  $\alpha=0.05$  level of significance and the results were: .*Ho: There is no significant relationship between Contract Financing and Construction Cost Overruns in real estate projects was rejected since  $P=0.000<0.05$ . Therefore the study concluded that there is significant influence of all financial and contract management approaches**

*as well as contracting on construction cost overruns in real estate projects.*

*Keywords:* contract financing, construction cost overrun, real estate projects.

*Author α:* Joanne A. Kepher – PhD student, University of Nairobi, Kenya.

*σ:* Prof. Raphael O. Nyonje, University of Nairobi, Kenya.

*ρ:* Prof. Charles M. Rambo, University of Nairobi, Kenya.

## I. INTRODUCTION

Cost overruns is a significant challenge in construction projects. The significance and linkage of the construction industry to economic growth and development of all sectors in a country cannot be underrated ((Durdyev, Omarov, and Ismail, 2017). The constraints of cost, time and quality contribute to performance of projects, the construction industry focuses its lenses on cost constraints as a result of past performances of various studied projects. Overruns in terms of cost and quality have attracted a wide range of research to an extent that it has become a global phenomenon and therefore proper reduction of construction cost is a recommendation by scholars as an aggregate for the successful completion of projects (Ahady, Gupta, and Malik, 2017). Reduction of construction cost overrun is key to project performance despite the fact that it has proved to be laborious in the construction industry (Alias, Zawawi, Yusof, and Aris, 2014).

Successful projects are supposedly the ones which meet the triple constraint standard where time, cost and quality are adequately achieved. Project success is subject to efficacy in management of the

cost element. The main objective of project owners is to have their projects executed within their approved budgets and this leads them to engage professionals such as quantity surveyors to specifically manage financial aspects of the construction on their behalf; they consider cost certainty very highly. Nevertheless, cost overruns are commonplace on construction projects (Cunningham, 2017).

Contract financing in construction of real estate has been researched in relation to financing of working capital. Financial institutions come to the aid of contractors through availing advance project funding at a high interest rate which affects profitability in contracts; on the other hand clients can facilitate contractors by giving advance payments to kick-start a project in time. There are various forms of contract financing to help small and medium contractors in under developed or developing countries but the one setback is their repayment mode is punitive only to the advantage of the financier (Rameezdeen, Palliyaguru and Amaratunga, 2006).

### 1.1 Research Objective

The objective of the study was to establish how Contract financing influence Construction Cost Overruns in real estate projects.

### 1.2 Research Hypothesis

Ho: There is no significant relationship between Contract Financing and construction Cost Overruns in real estate projects.

## II. LITERATURE REVIEW

### 2.1 Construction Cost Overruns in Real Estate Projects

This study adopted the definition of Construction Cost Overruns as a structured multidisciplinary analysis of control process aiming to reduce excess of actual construction cost over budget in real estate projects (Khodeir and Ghandour, 2018). Construction Cost Overruns refer to processes that include accurate estimates, complete designs, correct scheduling, planning for scope changes and efficient administration. Different scholars have conducted studies to assess the causes of cost overruns in construction

projects (Khodier and Ghandour, 2018; Niazi and Painting, 2017; Lind and Brunes, 2015; Doloi, 2013 and Rosenfed, 2013).

Out of the studies that were reviewed; Lind and Brunes (2015) and Khodeir and Ghandour, (2018) focused on the importance of competence, skills and value management in the management of cost overruns, Doloi (2013) on the other hand focused on the responsibilities of key stakeholders including clients, consultants, and contractors. On the other hand, Niazi and Painting (2017) established that cost overruns were caused by: corruption; delays in progress payment by clients; difficulties by contractors to financing projects; insecurity; decision by the owners to change order during construction; market inflation; mistakes and discrepancies in design documents; and the type of project bidding awards. Also, Rosenfed (2013) found that premature tender documents, numerous changes in the owners' requirements and unrealistically low tender-winning prices caused construction cost overrun.

Construction Cost Overruns in this study was viewed from the perspective of: accurate project estimates; correct plan; complete project designs; planning for changes in project scope; and efficient administration of projects. The findings of this study concurred with the findings of studies by (Khodier and Ghandour, 2018; Niazi and Painting, 2017; Lind and Brunes, 2015; Doloi, 2013 and Rosenfed, 2013). This study found that low priced projects cost more than expected at the end, project costs are controlled through accepting minimal claims during implementation, strict adherence to comprehensive designs at tendering stage minimize project claim, whenever there is proper coordination at the design level unexpected outcomes during implementation are minimized, escalations are experienced due to errors in project activity scheduling, incorporating scheduling techniques help to save project cost, planning for scope changes is a requisite to minimize project cost, regulation of project cost becomes harder due to wrong initial scope definition, proper coordination of projects minimize project cost and that precisely organized project activities ensure control of unanticipated expenses. Therefore, this study established the key indicators of reduction of cost overruns on

real estate projects in Kenya's Nairobi and Kisumu Counties.

## *2.2 Contract Financing and Construction Cost Overruns in Real Estate Projects*

Contract financing refers to the advances given to a contractor in form of advance payments, loan guarantees, performance based payments, progress on cost based payment and completion percentage based payment. Various studies have been conducted with regard to contract financing and the management of cost overruns in projects.

The World Bank Research and Policy Report highlights the fact that despite the important role Micro, Small and Medium Enterprises (MSMEs) play in the economy, they normally experience difficulties accessing finances and funding compared to the large enterprises (Abraham and Schmukler, 2017).

In view of this, Huang, Chiu, Mo and Marjerison (2018) conducted a study among Micro, Small and Medium Enterprises (MSMEs) in China with the aim of understanding the institutional environment of the crowdfunding industry. This is because of the largely unregulated regulatory frameworks, uncovered patterns of development, profiling crowdfunding platforms and analyzing the regulatory landscape. The study employed an extensive desk research using data collected from the public and private sectors, which was then analyzed alongside existing academic literature.

The study highlighted three business models that are used in real estate crowdfunding in China: Cooperative Building Model – which focuses solely on residential properties and the investors must be identified and confirmed; before the land is acquired. The investors can participate in the in-house development, designs and interior decorations; Marketing and Sales Model - these real estate projects are also solely used for residential properties. To promote sales of the houses, the real estate companies use fixed yield, lottery or auction of houses with discounted prices; and Wealth Management Model – used in real estate projects cover both residential and commercial properties. This model is the mainstream one adopted by real estate crowdfunding in China, (Huang, et al., 2018).

The study emphasized on the important role that crowdfunding plays in innovation and entrepreneurial-based economic development, thus the need for a regulatory framework that would help leverage advances of online financing technology to create an early-stage funding market place.

This would help facilitate capital formation while providing investor protections through education and training. The researchers noted that the risk associated with online financing required regulatory protection and collaboration with other entrepreneurial activities such as private sectors, incubators, accelerators and universities to build the culture of trust which is essential to promote web-based interactions.

Venture capital and private equity (VC and PE) funds majorly provide funds for projects that are considered risky but which have a high potential for growth. These types of funding infrastructure projects have increased considerably over the past decade. In this regard therefore, Sharma and Tripathi (2016) undertook a 10-year longitudinal study in India with the purpose of examining the various aspects of staging and decision-making with regard to VC and PE financing of their infrastructure investments. This study analyzed VC/PE investments in the Indian infrastructure sector during the 2004-2014 period using the Venture Intelligence database with a final sample consisting of 540 deals involving 233 VC and PE investments.

In relation to the foregoing, Cheng, Lv, Jin, Du and Chen (2016) conducted a study in China titled “Research on Investment and Financing Mode of Urban Infrastructure under Perspective of Cost Management”. The study posited that any city's survival and development, normally relies on the efficacy of its infrastructure which is directly determined by the magnitude of investment in construction. The researchers noted that the growth of the country's national urban infrastructure supply had not been in tandem with the pace of urbanization which expands the new demand for urban infrastructure, a factor that was attributed to inadequate monetary resources.

This study used data from various sources including the national bureau of economic analysis, the World Bank and the OECD to analyze the relationship between urban

infrastructure construction investment and urbanization rate and per capita GDP. For instance, data from China's Ministry of Construction showed that in 2004, the country's urban construction demand stood at 500 – 600 billion Yuan, while the actual urban construction was estimated at 475.4 billion. The study concluded that although the construction of infrastructure is a major determinant of urban competitiveness, decision-makers in major cities continue being in a dilemma with regard to financing the same.

In view of the fact that contract financing plays an important role in the reduction of cost overruns in projects, Downs and Xu (2015) conducted a study to examine the contrasting influence of portfolio lending and securitization in the resolution of distressed commercial real estate. The researchers further analyzed the effects of the economic and financial crisis on high commercial mortgages including the high default and delinquency rates.

The overall delinquency rate of commercial multifamily mortgages climbed to 13.03 % in 2012. The results of the study were statistically significant.

Three out of the five studies by Huang et al., (2018); Cheng et al., (2016); Downs and Xu (2015) used qualitative research methods with extensive desktop research and literature review. However, the utilization of secondary data for research is limiting because it does not take into account contextual factors that keep on changing.

Therefore, the researchers ought to have considered incorporating primary data to strengthen the findings from the secondary data. On the other hand, Larsen, et al. (2016), Mbithi and Okiro (2018) and Sharma and Tripathi (2016) employed quantitative approaches in their studies. From the foregoing therefore, the proposed study will use mixed method design.

This study found that advance payments should be availed to contractors, contractors should be supported with start-up costs, loan guarantees should be accessed by contractors, credit enhancement are important to contractors, payments upon accomplishment should be considered in projects, clear activity completion

measurement criteria should be availed by consultants, progress payments should be encouraged, payment application should be done correctly, percentage of work completed for a period payment should be used and that mismanaged overbilling of payment should be controlled to positively influence Construction Cost Overruns in Real Estate Projects. Hence, the study investigated the key indicators in contract financing and construction cost overruns in real estate projects in Kenya's Nairobi and Kisumu.

### *2.3 Theoretical Framework*

This study was guided by the Microeconomic Production Theory proposed by Lerner (1968) and focused on the concept of cost function in that theory. This is a build-up of the works of Cantarelli et al. (2010), and adopted from Lind and Bruner (2015). The theory studies the behaviour of individual firms in regards to fixation of price and output and their reaction to the changes in the demand and supply conditions; thus it seeks to determine the mechanism by which the different economic units attain the position of equilibrium proceeding from individual units to an industry or a market: in our case being the construction industry and specifically real estate projects.

### *2.4 Conceptual Framework*

This study has adopted a conceptual framework outlined in figure 1 indicating the relationship of the independent variables and dependent variables.

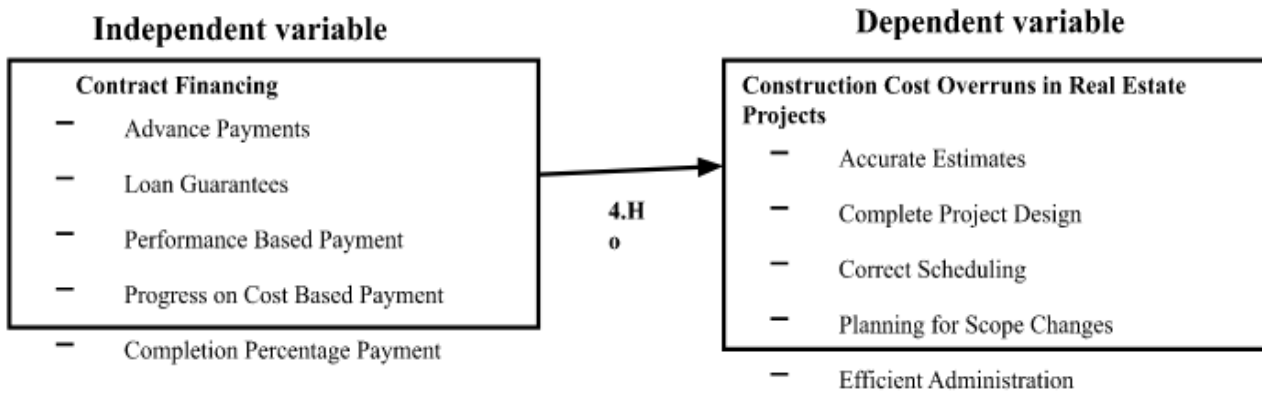

Figure 1: Conceptual Framework for Contract Financing of Construction Cost Overruns in Real Estate Project

### III. RESEARCH METHODOLOGY

This study used a descriptive survey research design and specifically; cross sectional survey as well as correlational research design. The descriptive research design used in this study helped to explore the link between the variables and report the way it is (Brook, 2013). Target population was based on the register of real estate projects between 2018 and 2019 held by the National Construction Authority (NCA) which had 570 active real estate projects comprising 95 in Kisumu and 475 in Nairobi Counties. In general, a typical real estate project structure comprises Project professionals such as Construction manager, clerk of works, Quantity Surveyor, Architect, Mechanical and Electrical engineer, structural Engineer, Contractor and Subcontractors. The 570 active real estate projects in Kisumu and Nairobi Counties each have at least one of the project professionals. Thus a minimum of 7 project professionals per real estate project constituted a target population of 4000 = (570×7) project professionals as well as 10 key informants.

A sample size of 351 was drawn from a target population of 4000 project professionals and key informants in Nairobi and Kisumu Counties. The sample size for the study was determined using Krejcie and Morgan table (Krejcie and Morgan, 1970). Based on the table, for a given population of 4000, a sample size of 351 was obtained and was further confirmed through hyper-geometric formula for a sample size as follows;

$$n = \frac{Z^2 N.P.(1-P)}{e^2(N-1)+Z^2P(1-P)} \frac{NZ^2 Pq}{(E^2(N-1)+Z^2)Pq}$$

Proportionate stratified and simple random sampling technique was used to select sample sizes from different strata (project professionals) out of the 570 active real estate projects registered and operating in Nairobi and Kisumu Counties; Purposive sampling was used to select key informants from a targeted population of ten having prerequisite experience in real estate development. Data for this study was collected in phases; pre-field work phase, field work phase and post-field work phase. The data collection was done by using a survey questionnaire.

### IV. RESULTS AND DISCUSSIONS

#### 4.1 Questionnaire Return Rate

Out of the sample size of 351 from the target population, 8 key informants were interviewed whereas 343 participants from the seven active real estates licensed to operate within Kisumu and Nairobi Counties by National Construction Authority were issued with questionnaires of which 336 duly filled and returned the questionnaires giving a return rate of 98%. Table 1 shows the Questionnaire Return Rate for the Project professionals from the seven active real estates licensed to operate within Kisumu and Nairobi Counties by National Construction Authority that were responded to and returned.

Table 1: Questionnaire Return Rate

County	Sampled	Returned	Return Rate%
Nairobi	287	281	81.92
Kisumu	56	55	16.04
<b>Total</b>	<b>343</b>	<b>336</b>	<b>97.96</b>

The high return rate was attained because the researcher consistently followed up all the sampled respondents during data collection. The high return rate of 98% facilitated gathering of sufficient data that could be generalized to determine the influence of Financial and Contract Management on Construction Cost Overruns in Real Estate Projects in Kisumu and Nairobi Counties. The Questionnaire return rate was considered adequate as per Mugenda and Mugenda (2003) and Kothari (2004) who recommended that a Questionnaire return rate beyond 50% is acceptable in research and subsequently satisfactory and contributes towards gathering of sufficient data that could be generalized to represent the opinions of participants.

#### 4.2 Demographic Characteristics of the Respondents

In order to understand the characteristics of participants the researcher was dealing with in the

study, their background information was necessary. The study sought information from the participants on distribution by position category in real estate projects, duration of profession in the organization and kind of construction projects conducted in real estate projects. The participants were asked to provide these demographic information.

**Distribution of Respondents by Position Category**  
It was imperative to investigate the respondents' position category to establish how financial and contract management of real estate projects were related with the cadre of the project professional whose information were considered to be significant to the construction agencies for policy decision making. The respondents were therefore asked to state their position category and the results are presented in Table 2.

Table 2: Distribution of Respondents by position category

Position category	Frequency	Cumulative frequency	Valid Percent	Cumulative percentage
Quantity Surveyor	41	41	12.20	12.20
Construction Manager/Clerk of works	66	107	19.60	31.80
Structural Engineer	49	156	14.60	46.40
Contractor	81	237	24.10	70.50
Architect	35	272	10.40	80.90
Mechanical and Electrical Engineer	40	312	11.90	92.80
Other Staff	24	336	7.20	100
<b>Total</b>	<b>336</b>		<b>100.00</b>	

Table 2, shows that 81(24.10%) were categorized as contractor project professionals, 66(19.60%) were categorized as Construction Manager/Clerk of work project professionals, 49(14.6%) were categorized as structural Engineers project professionals, 40(11.9%) were categorized as Mechanical and Electrical Engineer project professionals, 41(12.2%) were categorized as quantity surveyors, 35 (10.4%) were categorized as architects project professionals project

professionals and 24(7.2%) were categorized as other staff by project professionals. The findings on position category indicates that real estate projects are undertaken by qualified project professionals capable of responding to information sought on financial and contract management, project environment, organization capacity and construction cost overruns in real estate projects. Doloji (2012) established that position category by project professional is a

contributing factor on the relationship between financial contract management and construction cost overruns in real estate projects.

### 4.3 Basic Tests for Statistical Assumptions of Regression Analysis

The study was based on a set of assumptions of regression analysis that must be met to ensure the data collected is appropriate for the statistical analysis. When these assumptions are violated the results of the analysis can be erroneous. The assumptions tested include normality, linearity, multi-collinearity and independence of errors.

#### Assumptions of Normality

An assessment of the normality of data is a prerequisite for many statistical tests because normal data is an underlying assumption in parametric testing. The test for normality of data distribution was conducted on all the predictor variables, moderating variables using Kolmogorov-Smirnov test statistics (KS-test) and Shapiro-Wilk test (SW-test).

### 4.4 Contract Financing and Construction Cost Overruns in Real Estate Projects

Contract financing in this study refers to advances given to a contractor in the form of advance payments, loan guarantees, performance based payments, progress on cost based payment and completion percentage based payment. This was the fourth objective that the study sought to achieve; therefore, the participants were requested to give their opinions on their level of agreements or disagreements with the ten statements of Contracting process on a Likert scale of 1-5 where Strongly agree (SA)=5, Agree (A)=4 Neutral (N)=3, Disagree(D) = 2 and Strongly disagree. (SD)=1. The results were analyzed and presented using frequency, percentage, mean and standard deviation for each response in each item. The item mean as well as the standard deviation were also computed and presented alongside as provided in Table 3.

Table 3: Contract Financing and construction cost overruns in real estate projects

ITEMS	SA	A	N	D	SD	Mean	Std. dev
Advance payments should be availed to contractors	121(36%)	150(44.6%)	44(13.1%)	13(3.9%)	8(2.4%)	4.08	0.925
Contractors should be supported with start-up costs	112(33.3%)	167(49.7%)	48(14.3%)	5(1.5%)	4(1.2%)	4.13	0.793
Loan guarantees should be accessed by contractors	118(35.1%)	176(52.4%)	42(12.5%)	0(0.00%)	0(0.00%)	4.23	0.653
Credit enhancement are important to contractors	146(43.5%)	140(41.7%)	46(13.6%)	4(1.2%)	0(0.00%)	4.27	0.739
Payments upon accomplishment should be considered in projects	139(41.4%)	152(45.2%)	43(12.8%)	2(0.6%)	0(0.00%)	4.27	0.701
Clear activity completion measurement criteria should be availed by consultants	157(46.7%)	146(43.5%)	29(8.6%)	4(1.2%)	0(0.00%)	4.35	0.737
Progress payments should be encouraged	154(45.9%)	151(44.9%)	30(8.9%)	1(0.3%)	0(0.00%)	4.36	0.655
Payment application should be done correctly	177(52.7%)	134(39.9%)	25(7.4%)	0(0.00%)	0(0.00%)	4.45	0.631
Percentage of work completed for a period payment should be used	198(58.9%)	116(34.6%)	22(6.5%)	0(0.00%)	0(0.00%)	4.52	0.618
Mismanaged overbilling of payment should be controlled	197(58.7%)	115(34.2%)	24(7.1%)	0(0.00%)	0(0.00%)	4.51	0.628

The results in Table 3 indicate that the composite mean and composite Standard deviation for the Contract financing were 4.39 and 0.683 respectively; implying that using the Likert scale a majority of participants at least agreed (mean=4.39) that Contract financing influences Construction Cost Overruns in Real Estate Projects. Similarly ten statements were developed to measure the extent to which Contract financing influences reduction of Construction Cost Overruns in Real Estate Projects.

Statement (1) that 'Advance payment should be available to contractors' had a mean of 4.08 and a standard deviation of 0.925. These results indicate that out of 336 study participants, 121(36%) strongly agreed, 150(44.6%) agreed, 44(13.1%) were neutral, 13(3.9%) disagreed and 8(2.4%) strongly disagreed that advance payment should be available to contractors. This results shows that the line statement mean score of 4.08 was lower than the composite mean of 4.39. The implication of this result to the study is that there is need to avail advance payment to contractors in order to positively influence management of Construction Cost Overruns in Real Estate Projects. The study results support findings by Aje, Olatunji and Olalusi (2015) who found out that advance payment to contractors can be used as a means of preventing cost overruns in construction projects.

Statement (2) that 'Contractors should be supported with start –up costs' had a mean of 4.13 and a standard deviation of 0.793. These results indicate that out of 336 study participants, 112(33.3%) strongly agreed, 167(49.7%) agreed, 48(14.3%) were neutral, 5(1.5%) disagreed and 4(1.2%) strongly disagreed that contractors should be supported with start –up costs. This results shows that the line statement mean score of 4.13 was lower than the composite mean of 4.39. The implication of this result to the study is that there is a need to support contractors with start –up costs in order to positively influence management of Construction Cost Overruns in Real Estate Projects. The study results support findings by Meijers, Doree and Boes (2014) found that negotiated start –ups seem to reduce costs making them applicable to smaller projects where

high set up costs would not be justifiable due to their limited size, complexity, or cost.

Statement (3) that 'Loan guarantees should be accessed by contractors' had a mean of 4.23 and a standard deviation of 0.653. These results indicate that out of 336 study participants, 118(35.1%) strongly agreed, 176(52.4%) agreed and 42(12.5%) were neutral that loan guarantees should be accessed by contractors. This results shows that the line statement mean score of 4.23 was lower than the composite mean of 4.39. The implication of this result to the study is that there is a need for contractors to access loan guarantees in order to positively influence management of Construction Cost Overruns in Real Estate Projects. The study results support findings by Renaud (2012) who found that loan guarantees should not be over or under-regulated since overpricing of real estate causes moral hazard which could eventually lead to overruns.

Statement (4) that 'Credit enhancement is important to contractors' had a mean of 4.27 and a standard deviation of 0.739. These results indicate that out of 336 study participants, 146(43.5%) strongly agreed, 140(41.7%) agreed, 46(13.7%) were neutral and 4(1.2%) disagreed that credit enhancement is important to contractors. This results shows that the line statement mean score of 4.27 was lower than the composite mean of 4.39. The implication of this result to the study is that there is a need to enhance credit to contractors in order to positively influence management of Construction Cost Overruns in Real Estate Projects. The study results supported by Fan, Sing, Ong and Sirmans (2004) found that governance and optimal financing had unique features such as credit enhancement which were viewed as interesting financial innovations for the construction industry.

Statement (5) that 'Payment upon accomplishment should be considered in projects' had a mean of 4.27 and a standard deviation of 0.701. These results indicate that out of 336 study participants, 139(41.4%) strongly agreed, 152(45.2%) agreed, 43(12.8%) were neutral and 2(0.6%) disagreed that payment upon accomplishment should be considered in projects.

This results shows that the line statement mean score of 4.27 was lower than the composite mean of 4.39. The implication of this result to the study is that there is a need to consider payment upon accomplishment of projects in order to positively influence management of Construction Cost Overruns in Real Estate Projects. The study results contradicts findings by Omopariola, Windapo, Edwards and Thwala (2019) who found out that delay in payments, difficulty in obtaining financial aid and inadequate budgetary control are the causes of cash flow problems during construction projects which lead to cost overruns.

Statement (6) that 'Clear activity completion measurement criteria should be availed by consultants' had a mean of 4.35 and a standard deviation of 0.737. These results indicate that out of 336 study participants, 157(46.7%) strongly agreed, 146(43.5%) agreed, 29(8.6%) were neutral and 4(1.2%) strongly disagreed that clear activity completion measurement criteria should be availed by consultants. This results shows that the line statement mean score of 4.35 was lower than the composite mean of 4.39. The implication of this result to the study is that there is a need to conduct clear activity completion measurement criteria by consultants in order to positively influence Construction Cost Overruns in Real Estate Projects. The study results support finding by Eriksson (2017) found out that payment based on activity completion may enhance efficiency therefore reducing cost overruns.

Statement (7) that 'Progress payment should be encouraged' had a mean of 4.36 and a standard deviation of 0.655. These results indicate that out of 336 study participants, 154(45.9%) strongly agreed, 151(44.9%) agreed, 30(8.9%) were neutral and 1(0.3%) disagreed that progress payment should be encouraged. This results shows that the line statement mean score of 4.36 was lower than the composite mean of 4.39. The implication of this result to the study is that there is a need to encourage progress payment in order to positively influence management of Construction Cost Overruns in Real Estate Projects. The study results support findings by Perera and Dewagoda (2020) who found that progress payments should be made since delayed payments contribute to adverse consequences such as cost overruns.

Statement (8) that 'Payment application should be done correctly' had a mean of 4.45 and a standard deviation of 0.631. These results indicate that out of 336 study participants, 177(52.7%) strongly agreed, 134(39.9%) agreed and 25(7.4%) were neutral that payment applications should be done correctly. This results shows that the line statement mean score of 4.45 was higher than the composite mean of 4.39. The implication of this result to the study is that correctly done payment applications positively influence management of Construction Cost Overruns in Real Estate Projects. The study results support findings by Treacy, Spillane and Tansey (2014) found out that construction disputes in Ireland are as a result of payment factors that could emanate from payment application issues.

Statement (9) that 'Percentage of work completed for a period payment should be used' had a mean of 4.52 and a standard deviation of 0.618. These results indicate that out of 336 study participants, 198(58.9%) strongly agreed, 116(34.6%) agreed and 22(6.5%) were neutral that the percentage of work completed for a period payment should be used. This results shows that the line statement mean score of 4.52 was higher than the composite mean of 4.39. The implication of this result to the study is that use of percentage of work completed for a period payment positively influences management of Construction Cost Overruns in Real Estate Projects. The study results support findings by Perera and Dewagoda (2020) who found that proper strategies must be instituted to streamline management of delay in payment for works done.

Statement (10) that 'Mismanaged overbilling of payment should be controlled' had a mean of 4.51 and a standard deviation of 0.628. These results indicate that out of 336 study participants, 197(58.7%) strongly agreed, 115(34.2%) agreed and 24(7.1%) were neutral that mismanaged overbilling of payment should be controlled. This results shows that the line statement mean score of 4.51 was higher than the composite mean of 4.39. The implication of this result to the study is that control of mismanagement of overbilling positively influences management of Construction Cost Overruns in Real Estate Projects. The study results support finding by Agyekum, Adinyira and

Amudjie (2020) found that corrupt, fraudulent, collusive or coercive practices, client divulging more information to the preferred bidder and inflating tender prices led to mismanagement of construction payments.

#### 4.5 Correlation Analysis on Contract Financing and Construction Cost Overruns in Real Estate Projects

The study sought to examine the relationship between Contract financing and reduction of

construction cost overruns in real estate projects. Pearson correlation coefficient was used to test the relationship between Contract financing and reduction of construction cost overruns in real estate projects at 95% level of confidence. The correlations results obtained are shown in Table 4.

**Table 4:** Correlations of Contract Financing and Construction Cost Overruns in Real Estate Projects

Contract financing statements		Construction cost overruns in real estate projects
1. Advance payment should be availed to contractors	Pearson correlation	0.205*
	sig. (2-tailed)	0.000
	n	336
2. Contractors should be supported with start-up costs	Pearson correlation	0.147*
	sig. (2-tailed)	0.007
	n	336
3. loan guarantees should be accessed by contractors	Pearson correlation	0.177*
	sig. (2-tailed)	0.001
	n	336
4. credit enhancement are important to contractors	Pearson correlation	0.204
	sig. (2-tailed)	0.000
	n	336
5. payment upon accomplishment should be considered in projects	Pearson correlation	-0.009*
	sig. (2-tailed)	0.863
	n	336
6. clear activity completion measurement criteria should be availed by consultants	Pearson correlation	0.030*
	sig. (2-tailed)	0.584
	n	336
7. progress payment should be encouraged	Pearson correlation	0.025*
	sig. (2-tailed)	0.647
	n	336
8 payment application should be done correctly	Pearson correlation	-0.002*
	sig. (2-tailed)	0.967
	n	336
9 percentage of work completed for a period payment should be used	Pearson correlation	0.134*
	sig. (2-tailed)	0.014
	n	336
10. mismanaged overbilling of payment should be controlled	Pearson correlation	0.238*
	sig. (2-tailed)	0.000
	n	336
Contract financing (overall correlation)	Pearson correlation	0.180*
	Sig.(2-tailed)	0.001
	n	336

(n=336);\*Correlation is significant at 0.05 level (2-tailed)

To test the extent of the relationship between Contract financing and reduction of construction cost overruns in real estate projects; several

characteristics of Contract financing and reduction of construction cost overruns in real estate projects were analyzed based on the

following hypothesis; Ho: There is no significant relationship between Contract financing and reduction of construction cost overruns in real estate projects. The corresponding mathematical model for the hypothesis was identified as follows: reduction of construction cost overruns in real estate projects = f (Contract financing). The correlation results presented in Table 4.26 indicated that six out of ten statements of contract financing were significant since the P-values <0.05: (Statement 1; advance payment should be availed to contractors;  $r=0.205$ ,  $P\text{-value}=0.000<0.05$ , Statement 2; contractors should be supported with start-up costs;  $r=0.147$ ,  $P\text{-value}=0.007<0.05$ , Statement 3; loan guarantees should be accessed by contractors;  $r=0.177$ ,  $P\text{-value}=0.001<0.05$ , Statement 4; credit enhancement are important to contractors;  $r=0.204$ ,  $P\text{-value}=0.000<0.05$ , Statement 5; payment upon accomplishment should be considered in projects;  $r=-0.009$ ,  $P\text{-value}=0.863>0.05$ , Statement 6; clear activity completion measurement criteria should be availed by consultants;  $r=0.030$ ,  $P\text{-value}=0.584>0.05$ , Statement 7; progress payment should be encouraged;  $r=0.025$ ,  $P\text{-value}=0.647>0.05$ , Statement 8; payment application should be done correctly;  $r=-0.002$ ,  $P\text{-value}=0.967>0.05$ , Statement 9; percentage of work completed for a period payment should be used;  $r=0.134$ ,  $P\text{-value}=0.014<0.05$  and Statement 10; mismanaged overbilling of payment should be controlled;  $r=0.238$ ,  $P\text{-value}=0.000<0.05$ ).

In order to determine the correlation between Contract financing and construction cost overruns, Pearson correlation coefficient was run on the scores of each scale. The total scores of the scales were computed as a summation of the individual scores on each item by the respondent at 95% level of confidence. The study found a positive overall correlation ( $r=0.180$ ) which was statistically significant as  $P<0.05$  ( $p=0.001$ )

between Contract financing and construction cost overruns in real estate projects; implying that there is a significant relationship between Contract financing and construction cost overruns in real estate projects leading to rejection of the null hypothesis (Ho: There is no significant relationship Contract financing and construction cost overruns in real estate projects) and acceptance of the alternative hypothesis, and hence the research findings conclude that there is a significant relationship between Contract financing and construction cost overruns in real estate projects. This finding is in agreement with findings by Ali, Azmi and Baaki (2017) study that found out that there is a significant relationship between Contract financing and cost overruns in construction projects.

#### 4.6 Regression Analysis of Contract Financing and Construction Cost Overruns in Real Estate Projects

Simple linear regression was adopted to investigate how Contract financing influence the construction cost overruns in real estate projects. It was necessary to get the views of the participants on the influence of Contract financing on construction cost overruns in real estate projects. The rationale of using the simple regression model was to establish how Contract financing as a predictor significantly or insignificantly predicted the construction cost overruns in real estate projects.

##### 4.6.1 Model summary of Contract Financing and Construction Cost Overruns in Real Estate Projects

The model summary sought to determine how Contract financing is a predictor that significantly or insignificantly predicted construction cost overruns in real estate projects. The regression model summary results are presented in Table 5.

**Table 5:** Regression Model Summary table of Contract Financing and Construction Cost Overruns in Real Estate Projects

Model Summary				
Model	R	R Square	Adjusted R Square	Std. Error of the Estimate
1	0.180 <sup>a</sup>	0.0324	0.032	3.59168
a. Predictors: (Constant), Contract financing				

The model summary table suggests that there is a positive correlation ( $R=0.188$ ) between Contract financing and construction cost overruns in real estate projects and those predicted by the regression model. In addition, 3.5% of the variation in the construction cost overruns in real estate projects is explained by Contract financing. The results are consistent with the findings of a study by Ali, Azmi and Baaki (2017) who found out that a regression model for refurbishment cost prediction indicates that procurement strategy, incompetent contractors, availability of funding, materials and equipment, and force majeure were

significant predictors of building refurbishment cost performance which is equivalent to construction cost overruns.

#### 4.6.2 ANOVA of Contract Financing and Construction Cost Overruns in Real Estate Projects

The study sought to establish if the regression model is best fit for predicting construction cost overruns in real estate projects after use of Contract financing. The ANOVA results are presented in Table 6.

**Table 6:** An ANOVA of the Regression of Contract financing and Reduction of Construction Cost Overruns in Real Estate Projects

Model		Sum of Squares	df	Mean Square	F	Sig.
1	Regression	157.335	1	157.335	12.196	0.001 <sup>b</sup>
	Residual	4308.653	334	12.900		
	Total	4465.988	335			
a. Dependent Variable: <b>construction cost overruns in real estate projects</b>						
b. Predictors: (Constant), Contract financing						

The ANOVA results indicated that (F-statistics (1,334)=12.196 is significant since the P-value  $0.001 < 0.05$  implying that the predictor co-efficient is at least not equal to zero. and hence the regression model results in significantly better prediction of construction cost overruns in real estate projects. The results are consistent with the findings of a study by Durdyey (2020) who found out that Contract financing significantly predicts better Construction cost overruns in real estate projects.

#### 4.6.3 Coefficients for Regression of Contract Financing and Construction Cost Overruns in Real Estate Projects

The study sought to establish whether there was influence of Contract financing and Construction cost overruns in real estate projects. The regression coefficients results are presented in Table 7.

**Table 7:** Coefficients for the Regression of Contract financing and Construction Cost Overruns in Real Estate Projects

Coefficients						
Model		Unstandardized Coefficients		Standardized Coefficients	t	Sig.
		B	Std. Error	Beta		
1	(Constant)	37.169	1.916		19.394	0.000
	Contract financing	0.154	0.044	0.180	3.492	0.001

*Dependent Variable:* construction cost overruns in real estate projects  
The simple linear regression coefficients result indicated that there was significant influence of Contract financing on construction cost overruns

in real estate projects. The coefficient of the constant term ( $\beta_0 = 37.169$ ; P-value= $0.000 < 0.05$ ) and Contract financing ( $\beta_4 = 0.154$ ; P-value= $0.001 < 0.05$ ) were statistically significant. The regression model for Contracting Process was

$y=37.169 + 0.154X_4$  implying that for each unit of Contract financing, construction cost overruns in real estate projects marginally changed by 0.154 units. It was therefore concluded that Contract financing and reduction of construction cost overruns in real estate projects were positively and linearly related. The results are consistent with the findings of a study by Ingle, Mahesh and Deepak (2020) who found out that Contract financing and Construction cost overruns in real estate projects were positively and linearly related.

## V. CONCLUSIONS AND RECOMMENDATIONS

The research objective was to examine the extent to which Contract Financing influence Construction Cost Overruns in Real Estate Projects. The simple linear regression coefficients as well as the Pearson correlation results indicated that there was significant influence of Contract Financing on Construction Cost Overruns in Real Estate Projects. The small p-values; implied that there was a significant influence of Contract Financing on Construction Cost Overruns in Real Estate Projects.

Considering the study findings and conclusions, the following recommendations were made: Project professionals and other relevant real estate project stakeholders should ensure that correct payment application is done accurately and payment upon accomplishment of project activities is given due consideration to avoid unnecessary cost overruns.

## VI. LIMITATIONS OF THE STUDY

The study involved project professionals in interviews, these are busy people and therefore adequate time was required to schedule meetings with them. The challenge was mitigated through allocating sufficient time for appointments and increased use of online technology for both communication and data collection. The period when the proposed study was envisioned to take place was marred with great uncertainty of events due to coronavirus pandemic but this was mitigated through flexibility of adapting the most effective and functional technology to reach the proposed respondents.

## REFERENCES

1. Abraham & Schmukler, (2017). "Financial Globalization: A Glass Half Empty?" Policy Research Working study. World Bank Group 8194.
2. Agyekum K., Adinyira, E. and Amudjie, J. (2020), "Ethical misconducts within the invitation to tender and tender and tender evaluation and award stages of construction contracts in Ghana", *Journal of Engineering, Design and Technology*, DOI: 10.1108/ JEDT-07-2020-0274.
3. Ahady, S., Gupta, S. and Malik, R.K. (2017) A critical review of the causes of cost overrun in construction industries of developing countries. *International Research Journal of Engineering and Technology*, 4(3), pp.2550 -2558
4. Aje I., Olatunji O. & Olalusi O. (2015). Overrun Causations under Advance Payment Regimes. *Built Environment Project and Asset Management*. 7.86-98.10.1108/BEPAM-06-20 15-0028.
5. Ali A.S, Azmi N.F & Baaki T K (2017) Cost performance of building refurbishment works: the case of Malaysia. *International Journal of Building Pathology and Adaptation*, 36(01), 41–62.
6. Alias Z, Zawawi E.M.A, Yusof K, Aris N.M (2014). Determining critical success factors of project management practice: A conceptual framework. *Procedia: Social and Behavioral Sciences*, 153: 61–69
7. Brooke J., (2013). "SUS-A quick and dirty usability scale (in Usability Evaluation in Industry)" London publisher
8. Cantarelli, C., Flyvbjerg, B., Molin, E.J.E. & van Wee, B. (2010) "Cost Overruns in Large-Scale Transportation Infrastructure Projects: Explanations and their Theoretical Embeddedness". *European Journal of Transport and Infrastructure Research*, 10(1), 5–18.
9. Cheng, Lv, Jin, Du & Chen, (2016). "Investment and Financing Mode of Urban Infrastructure under Perspective of Cost Management".
10. Cunningham, T. (2017), "Cost Control During the Pre-Contract Stage of a Building Project" – An Introduction, Arrow, Dublin Institute of

- Technology, online: <http://arrow.dit.ie/beschreoth/49/>
11. Doloi, H. (2012). "Analyzing Factors Affecting Delays in Indian Construction Projects." *International Journal Project Management*, 30(4), 479–489.
  12. Doloi, H. (2013). "Cost Overruns and Failure in Project Management: Understanding the Roles of Key Stakeholders in Construction Projects". *Journal of Construction Engineering and Management*, 139, 267–79.
  13. Downs & Xu (2015). "Commercial Real Estate, Distress and Financial Resolution: Portfolio Lending Versus Securitization".
  14. Durdyev Serdar. (2020). Review of construction journals on causes of project cost overruns. *Engineering Construction & Architectural Management*. 10.1108/ECAM-02-2020-0137.
  15. Durdyev, S., Omarov, M. and Ismail, S. (2017). SWOT Analysis of the Cambodian construction industry within the ASEAN economic community, *Proceedings of the 28th International Business Information Management Association Conference*, Seville, November 9-10.
  16. Eriksson, P.E. (2017), "Procurement strategies for enhancing exploration and exploitation in construction projects", *Journal of Financial Management of Property and Construction*, Vol. 22 No. 2, pp. 211-230. <https://doi.org/10.1108/JFMPC-05-2016-0018>.
  17. Fan Gang-Zhi, Sing Tien, Ong Seow Eng & Sirmans, C.. (2004). Governance and optimal financing for asset-backed securitization. *Journal of Property Investment & Finance*. 22. 414-434. 10.1108/14635780410556898.
  18. Huang, Chiu, Mo & Marjerison (2018). "The Nature of Crowdfunding in China: Initial Evidence", *Asia Pacific Journal of Innovation and Entrepreneurship*.
  19. Ingle Prachi, Mahesh Gangadhar & MD, Deepak. (2020). Identifying the performance areas affecting the project performance for Indian construction projects. *Journal of Engineering Design and Technology*. 19. 1-20. 10.1108/JEDT-01-2020-0027.
  20. Khodeir & Ghandour, (2018). "Examining the Role of Value Management in Controlling Cost Overrun (Application on Residential Construction Projects in Egypt)"
  21. Kothari, C. R. (2004), "Research Methodology -Methods and Techniques". 2nd revised edition. Published by New age international publisher. Page 32. Kotval and Mullin.
  22. Krejcie, R.V., & Morgan, D.W. (1970). "Determining Sample Size for Research Activities". *Educational and Psychological Measurement*, 30, 607-610.
  23. Larsen JK., GQ Shen, SM Lindhard & Brunoe TD, (2016), "Factors Affecting Schedule Delay, Cost Overruns, and Quality Level in Public Construction Project", *Journal of Management in Engineering* 32 (1), 04015032
  24. Lerner, A. P. (1968) "Microeconomic Theory", Printed in *Perspectives in Economics*, edited by Brown, Neuberger and Palmatier (Preliminary edition), p. 30.
  25. Lind & Brunos, F., (2015). "Explaining Cost Overruns in Infrastructure Projects: A New Framework with Applications to Sweden". *Construction Management Economics*. 33 (7), 554–568.
  26. Mbithi, P., & Okiro, K. (2018). Determinants of Private Finance Initiative for Project Financing; A Study of National Road Construction Projects in Kenya. *African Development Finance Journal*, 2(4), 15-29.
  27. Meijers, S.J., Dorée, A.G. and Boes, H. (2014), "Increased cooperation through immediate post contractual negotiation", *Journal of Public Procurement*, Vol. 14 No. 4, pp. 567-583. <https://doi.org/10.1108/JOPP-14-04-2014-B005>.
  28. Mugenda, O. M. & Mugenda, A. G. (2003). "Research methods: Quantitative and qualitative Approaches". Nairobi: African Centre for Technology Studies.
  29. Niazi G. A. & Painting N. (2017). "Significant Factors Causing Cost Overruns in the Construction Industry in Afghanistan" *Procedia Engineering* 182 510.
  30. Omopariola E., Windapo A., Edwards D., & Thwala W.. (2019). Contractors' perceptions of the effects of cash flow on construction projects. *Journal of Engineering, Design and Technology*. ahead-of-print. 10.1108/JEDT-04-2019-0099.
  31. Perera B.A.K.S. and Dewagoda K.G. (2020), "Streamlining the management of payment delays: the case of Sri Lankan Government

- building construction projects", *Journal of Financial Management of Property and Construction*, Vol. ahead-of-print No. ahead-of-print. <https://doi.org/10.1108/JFMPC-05-2020-0041>.
32. Rameezdeen R., Palliyaguru R. S. & Amaratunga D. (2006). Financing contractors in developing countries: Impact of mobilization advance payment. In *Proceedings of the 3rd International SCRI Symposium* (pp. 153-165).
  33. Renaud, B. (2012). Real Estate Bubble and Financial Crisis in Dubai: Dynamics and Policy Responses. *Journal of Real Estate Literature*, 20(1), 51-78. Retrieved May 29, 2021, from <http://www.jstor.org/stable/24884146>.
  34. Rosenfed (2013). "Root-Cause Analysis of Construction-Cost Overruns", *Journal of Construction Engineering and Management*, 10(1), pp.1-10. Richard O. Asiedu and Hans W. Alfen 22.
  35. Sharma & Tripathi, (2016). "Staged Financing as a Means to Alleviate Risk in VC/PE Financing"
  36. Treacy D., Spillane J. P. & Tansey, P. (2014). Construction Disputes in Small to Medium Enterprises in Ireland during Recession: Identification of Critical Factors. *International Journal of Law and the Built Environment*, 8(1), 21-41. <https://doi.org/10.1108/IJLBE-10-2014-0031>.

*This page is intentionally left blank*



Scan to know paper details and  
author's profile

# Negotiation Strategies on Construction Cost Overruns in Real Estate Projects: Nairobi and Kisumu Counties, Kenya

*Joanne A. Kepher, Prof. Raphael O. Nyonje & Prof. Charles M. Rambo*

*University of Nairobi*

## ABSTRACT

Cost overruns have provided a significant challenge in the construction industries of both developed and developing countries. Financial and Contract Management incorporate designs and approaches which take keen interest on issues associated to Negotiation Strategies which informed the basis of investigation of the concept of Construction Cost Overruns in Real Estate Projects in this study. The purpose of this study was to investigate the influence Negotiation Strategies on Construction Cost Overruns of real estate projects in Nairobi and Kisumu Counties. The study was guided by objectives to establish the extent to which Negotiation Strategies influence construction cost overruns in real estate projects. The study was based on pragmatic paradigm which provides for the use of both qualitative and quantitative research methodologies. The research adopted descriptive survey and correlational research designs.

*Keywords:* negotiation strategies, construction cost overrun, real estate projects.

*Classification:* DDC Code: 658.1511 LCC Code: HF5657.4

*Language:* English



LJP Copyright ID: 392952

Print ISSN: 2631-8474

Online ISSN: 2631-8482

London Journal of Engineering Research

Volume 22 | Issue 4 | Compilation 1.0



# Negotiation Strategies on Construction Cost Overruns in Real Estate Projects: Nairobi and Kisumu Counties, Kenya

Joanne A. Kephr<sup>α</sup>, Prof. Raphael O. Nyonje<sup>σ</sup> & Prof. Charles M. Rambo<sup>ρ</sup>

## ABSTRACT

*Cost overruns have provided a significant challenge in the construction industries of both developed and developing countries. Financial and Contract Management incorporate designs and approaches which take keen interest on issues associated to Negotiation Strategies which informed the basis of investigation of the concept of Construction Cost Overruns in Real Estate Projects in this study. The purpose of this study was to investigate the influence Negotiation Strategies on Construction Cost Overruns of real estate projects in Nairobi and Kisumu Counties.*

*The study was guided by objectives to establish the extent to which Negotiation Strategies influence construction cost overruns in real estate projects. The study was based on pragmatic paradigm which provides for the use of both qualitative and quantitative research methodologies. The research adopted descriptive survey and correlational research designs. The study targeted a population of 4000 project professionals that are 7 from active real estates in Nairobi and Kisumu Counties and 10 key informants from the real estate industry. Using the Krejcie and Morgan table of sampling method, the sample size for this study was 351. The study then adopted stratified, simple random and purposive sampling methods to select appropriate sample sizes from the study population. Structured questionnaire was the main instrument for data collection, supported by interview guide. Hypothesis tested at  $\alpha=0.05$  level of significance and the results were: *H<sub>0</sub>: There is no significant relationship between Negotiation Strategies and Construction Cost Overruns in real estate projects was rejected since  $P=0.000<0.05$ . Therefore the study concluded that there is significant influence of all financial and contract management a pproaches**

*as well as contracting on construction cost overruns in real estate projects.*

**Keywords:** negotiation strategies, construction cost overrun, real estate projects.

**Author α:** Joanne A. Kepher – PhD student, University of Nairobi, Kenya.

**σ:** Prof. Raphael O. Nyonje, University of Nairobi, Kenya.

**ρ:** Prof. Charles M. Rambo, University of Nairobi, Kenya.

## I. INTRODUCTION

Cost overruns is a significant challenge in construction projects. The significance and linkage of construction industry to economic growth and development of all sectors in a country cannot be underrated ((Durdyev, Omarov, and Ismail, 2017). The constraints of cost, time and quality contribute to performance of projects, the construction industry focuses its lenses on cost constraint as a result of past performances of various studied projects.

Overruns in terms of cost and quality have attracted a wide range of research to an extent that it has become a global phenomenon and therefore proper reduction of construction cost is a recommendation by scholars as an aggregate for the successful completion of projects (Ahady, Gupta, and Malik, 2017). Reduction of construction cost overrun is key to project performance despite the fact that it has proved to be laborious in the construction industry (Alias, Zawawi, Yusof, and Aris, 2014).

Successful projects are supposedly the ones which meet the triple constraint standard where time, cost and quality are adequately achieved. Project success is subject to efficacy in management of the cost element. The main objective of project

owners is to have their projects executed within their approved budgets and this leads them to engage professionals such as quantity surveyors to specifically manage financial aspects of the construction on their behalf; they consider cost certainty very highly. Nevertheless, cost overruns are commonplace on construction projects (Cunningham, 2017).

Negotiation strategies are employed in majority of construction projects in the 20th century where tendering comprises an award of contract to a contractor by the client after meeting a rigorous evaluation process which involves a number of other contractors. There are varied criteria of selection depending on one client to another with basics such as contractor's registration by regulating authorities, experience, financial position and equipment almost featuring in all evaluations. Some clients strictly rely on the competitive tendering processes to select a contractor while others move further to negotiate with a few of the selected contractors to decide on the one that fits in their other requirement (Kang, Elbasher, Tang, Jin and Tang, 2018).

### 1.1 Research Objective

The objective of the study was to determine how Negotiation strategies influence Construction Cost Overruns in real estate projects.

### 1.2 Hypothesis of the Study

Ho: There is no significant relationship between negotiation strategies and construction Cost Overruns in real estate projects.

## II. LITERATURE REVIEW

### 2.1 Construction Cost Overruns in Real Estate Projects

This study adopted the definition of Construction Cost Overruns as a structured multidisciplinary analysis of control process aiming to reduce excess of actual construction cost over budget in real estate projects (Khodeir and Ghandour, 2018). Construction Cost Overruns refer to processes that include accurate estimates, complete designs, correct scheduling, planning for scope changes and efficient administration. Different scholars have conducted studies to

assess the causes of cost overruns in construction projects (Khodier and Ghandour, 2018; Niazi and Painting, 2017; Lind and Brunes, 2015; Doloi, 2013 and Rosenfed, 2013).

Out of the studies that were reviewed; Lind and Brunes (2015) and Khodeir and Ghandour, (2018) focused on the importance of competence, skills and value management in the management of cost overruns, Doloi (2013) on the other hand focused on the responsibilities of key stakeholders including clients, consultants, and contractors. On the other hand, Niazi and Painting (2017) established that cost overruns were caused by: corruption; delays in progress payment by clients; difficulties by contractors to financing projects; insecurity; decision by the owners to change order during construction; market inflation; mistakes and discrepancies in design documents; and the type of project bidding awards. Also, Rosenfed (2013) found that premature tender documents, numerous changes in the owners' requirements and unrealistically low tender-winning prices caused construction cost overrun.

Construction Cost Overruns in this study was viewed from the perspective of: accurate project estimates; correct plan; complete project designs; planning for changes in project scope; and efficient administration of projects. The findings of this study concurred with the findings of studies by (Khodier and Ghandour, 2018; Niazi and Painting, 2017; Lind and Brunes, 2015; Doloi, 2013 and Rosenfed, 2013). This study found that low priced projects cost more than expected at the end, project costs are controlled through accepting minimal claims during implementation, strict adherence to comprehensive designs at tendering stage minimize project claim, whenever there is proper coordination at the design level unexpected outcomes during implementation are minimized, escalations are experienced due to errors in project activity scheduling, incorporating scheduling techniques help to save project cost, planning for scope changes is a requisite to minimize project cost, regulation of project cost becomes harder due to wrong initial scope definition, proper coordination of projects minimize project cost and that precisely organized project activities ensure control of un-anticipated expenses. Therefore, this study

established the key indicators of reduction of cost overruns on real estate projects in Kenya's Nairobi and Kisumu Counties.

## *2.2 Negotiation Strategies and Construction Cost Overruns in Real Estate Projects*

Negotiation strategies refer to methods such as structural technique, strategic technique, behavioural/diplomatic treaties, concession exchange and integrative techniques. Numerous scholars have conducted studies with regard to negotiation strategies and Reduction of Construction Cost Overruns. Zillante, Read and Seiler (2019) in their study test the loss aversion premise of prospect theory by considering whether uncertainty in the duration of negotiations with a prospective real estate developer affects the behavior of landowners faced with different fallback positions. The study which used experimental design found that, loss aversion may help explain the negotiating behavior of parties participating in a variety of different markets, including the real estate market where price negotiation is a common practice.

The study which was conducted using 113 respondents postulated that the incentive for landowners to accept offers to avoid eminent domain was limited by the weaker offers made by developers because of the possibility of the completion of assemblage without landowners' consent. The study further revealed that the more advantageous fallback positions tended to increase the bargaining power of landowners participating in land aggregation tasks. They also illustrated the importance of incorporating uncertainty into the duration of negotiations in economic experiments involving purchase and sale transactions, irrespective of whether those transactions involve land aggregation or some other type of proposed acquisition.

The study concluded that pre-contract negotiation was likely to increase the level of favorable outcome received by the contractors from the contract administrators' decision. They associated higher levels of pre-contract negotiation with a higher quality of decision making, which then translated into lower intensity of conflict. Higher levels of pre-contract negotiation were also associated with a higher quality of decision

making, while higher levels of the quality of the decision-making process were associated with a lower intensity of conflict.

In addition to the foregoing, Wachowicz, Kersten and Roszkowska (2018) conducted a study that sought to establish whether different principal's preference visualization schemes influence the accuracy of the agents' ratings. The researchers also wanted to establish the impact of (in) accuracy of the representation of the principal's preferences on the agreements negotiated by the agents and the agents' perception of the negotiation process and these agreements. The study was conducted on a sample of 362 students who were samples from Austria, Canada, China, Great Britain, Holland, Poland, Taiwan and Ukraine.

The study established that the fraction of agents that were able to define the scoring systems in accordance with the principals preferred information. The researchers also noted that over three quarters of the agents made at least one mistake while mapping the ordinal structure of preferences of their principal into the numerical scoring system, while the preference visualization used in the two studies seemed to affect the accuracy of scoring systems built by agents differently. Additionally, it was necessary to put into place additional mechanisms that should be implemented in the pre-negotiation protocol to ensure the increase in ordinal accuracy. The study further revealed that the accuracy of the scoring systems determined by the agents impacted the result that were obtained, both in the virtual quality perceived by both the agents and their principals, (Wachowicz, et al., 2018).

The study concluded that on one hand, the progress seeking and issues focused tactics were determined to be the most versatile. With moderating effects, progress seeking were found to enable negotiators to lower the expectations of the other parties by highlighting the importance of detaching their interests from the issue in focus and negotiating on the basis of positions and compromise.

In a different quantitative study conducted in Kenya, Ndihi and Noor (2019) sought to determine how post-tender negotiations

influenced the performance in commercial State Corporations. Descriptive design was employed on a sample of 108 respondents who were sampled from departments involved in the procurement related matters in 27 commercial state corporations. The study established that past experience in similar assignments and environments, and the proposed team contractors', were among key parameters that were used to select the contractors invited to bid for the work supplier capability and payment terms affected the performance in commercial State Corporations. The study concluded that, delays experienced in the procurement of materials and equipment were as a result of the different parties involved since the contractors were responsible for procurement. Also, the inability of contractors to ensure sufficient cash to meet his financial obligations when implementing the projects was cited as a major cause of cost and time overruns.

Nevertheless, the researchers used descriptive study design which was inappropriate because of the use of regression analysis. Descriptive design focuses on what questions and is concerned with describing the characteristics of a particular individual, or of a group as they are (Kothari, 2004; de Vaus, 2001)). Because of this, the design cannot be used with regression analysis nor can it be used to test hypothesis. The researchers should have used a different design such as ex-post facto or causal comparative. This study used a more robust research design in order to ensure that the results are rigorous enough. While Zillante, et al. (2019); Aibinu (2006); Wachowicz, et al. (2018); Ndihi and Noor (2019), and Cheung, et al. (2009) employed quantitative approaches, Pannebakker (2013) conducted a qualitative study. This study took a mixed method approach in order to capitalize on the strengths of both quantitative and qualitative methods.

The findings of this current study clearly define goals in negotiations, setting measurable targets in negotiations, setting clear expectations during negotiations, upholding negotiated terms, clarified roles and responsibilities during negotiations, adequate education and information on parties roles during negotiation, ensuring proper identification of potential partners mutual

interest during negotiation, availing well developed operational plan of potential partner during negotiation, organized consultative engagement at the beginning of a project and avoiding dictatorial approach in stakeholder engagement ensures proper negotiation techniques. Therefore, this study established all the proposed constructs of proper negotiation techniques positively influenced reduction of construction cost overruns in real estate projects in Kenya's Nairobi and Kisumu Counties.

### *2.3 Theoretical Framework*

This study was guided by the Microeconomic Production Theory proposed by Lerner (1968) and focused on the concept of cost function in that theory. This is a build-up of the works of Cantarelli et al. (2010), and adopted from Lind and Brunes (2015). The theory studies the behaviour of individual firms in regards to fixation of price and output and their reaction to the changes in the demand and supply conditions; thus it seeks to determine the mechanism by which the different economic units attain the position of equilibrium proceeding from individual units to an industry or a market: in our case being the construction industry and specifically real estate projects.

### *2.4 Conceptual Framework*

This study has adopted a conceptual framework outlined in figure 1 indicating the relationship of the independent variables and dependent variable.

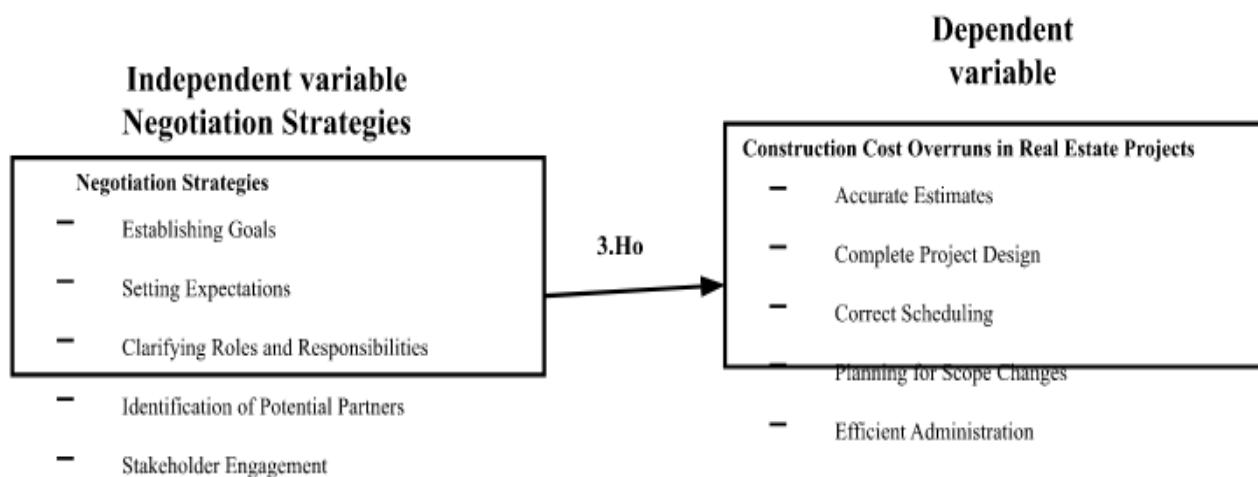

Figure 1: Conceptual Framework for Negotiation Strategies on Construction Cost Overruns in Real Estate Project

### III. RESEARCH METHODOLOGY

Data was analyzed using descriptive statistics and inferential statistics. Descriptive statistics used measures of central tendency such as frequency, percentage, mean, standard deviations, composite mean and composite standard deviation. Whereas inferential statistics used spearman correlation and regression analyses. The descriptive research design used in this study helped to explore the link between the variables and report the way it is (Brook, 2013). Target population was based on the register of real estate projects between 2018 and 2019 held by the National construction Authority (NCA) which had 570 active real estate projects comprising of 95 in Kisumu and 475 in Nairobi Counties. In general, a typical real estate project structure comprises Project professionals such as Construction manager, clerk of works, Quantity Surveyor, Architect, Mechanical and Electrical engineer, structural Engineer, Contractor and Subcontractors. The 570 active real estate projects in Kisumu and Nairobi Counties each have at least one of the project professional. Thus a minimum of 7 project professional per real estate project constituted a target population of 4000 = (570×7) project professional as well as 10 key informants.

A sample size of 351 was drawn from a target population of 4000 project professional and key informants in Nairobi and Kisumu Counties. The sample size for the study was determined using Krejcie and Morgan table (Krejcie and Morgan,

1970). Based on the table, for a given population of 4000, a sample size of 351 was obtained and was further confirmed through hyper-geometric formula for a sample size as follows;

$$n = \frac{Z^2 N.P.(1-P)}{e^2(N-1)+Z^2P(1-P)} \frac{NZ^2 Pq}{(E^2(N-1)+Z^2)Pq}$$

Proportionate stratified and simple random sampling technique was used to select sample sizes from different strata (project professionals) out of the 570 active real estate projects registered and operating in Nairobi and Kisumu Counties; Purposive sampling was used to select key informants from a targeted population of ten having prerequisite experience in real estate development. Data for this study was collected in phases; pre-field work phase, field work phase and post-field work phase. The data collection was done by using survey questionnaire and interview guide.

### IV. RESULTS AND DISCUSSIONS

#### 4.1 Questionnaire Return Rate

Out of the sample size of 351 from the target population, 8 key informants were interviewed whereas 343 participants from the seven active real estates licensed to operate within Kisumu and Nairobi Counties by National Construction Authority were issued with questionnaires of which 336 dully filled and returned the questionnaires giving a return rate of 98%. Table 1 shows the Questionnaire Return Rate for the

Project professionals from the seven active real estates licensed to operate within Kisumu and

Nairobi Counties by National Construction Authority that were responded to and returned.

*Table 1: Questionnaire Return Rate*

County	Sampled	Returned	Return Rate%
Nairobi	287	281	81.92
Kisumu	56	55	16.04
<b>Total</b>	<b>343</b>	<b>336</b>	<b>97.96</b>

The high return rate was attained because the researcher consistently followed up all the sampled respondents during data collection. The high return rate of 98% facilitated gathering of sufficient data that could be generalized to determine the influence of Financial and Contract Management on Construction Cost Overruns in Real Estate Projects in Kisumu and Nairobi Counties. The Questionnaire return rate was considered adequate as per Mugenda and Mugenda (2003) and Kothari (2004) who recommended that a Questionnaire return rate beyond 50% is acceptable in research and subsequently satisfactory and contributes towards gathering of sufficient data that could be generalized to represent the opinions of participants.

#### 4.2 Demographic Characteristics of the Respondents

In order to understand the characteristics of participants the researcher was dealing with in the

study, their background information was necessary. The study sought information from the participants on distribution by, position category in real estate projects, duration of profession in the organization and kind of construction projects conducted in real estate projects. The participants were asked to provide these demographic information.

**Distribution of Respondents by Position Category**  
 It was imperative to investigate the respondents' position category to establish how financial and contract management of real estate projects were related with cadre of the project professional whose information were considered to be significance to the construction agencies for policy decision making. The respondents were therefore asked to state their position category and the results are presented in Table 2.

*Table 2: Distribution of Respondents by position category*

Position category	Frequency	Cumulative frequency	Valid Percent	Cumulative percentage
Quantity Surveyor	41	41	12.20	12.20
Construction Manager/Clerk of works	66	107	19.60	31.80
Structural Engineer	49	156	14.60	46.40
Contractor	81	237	24.10	70.50
Architect	35	272	10.40	80.90
Mechanical and Electrical Engineer	40	312	11.90	92.80
Other Staff	24	336	7.20	100
<b>Total</b>	<b>336</b>		<b>100.00</b>	

Table 2, shows that 81(24.10%) were categorized as contractor project professionals, 66(19.60%) were categorized as Construction Manager/Clerk of work project professionals, 49(14.6%) were

categorized as structural Engineers project professionals, 40(11.9%) were categorized as Mechanical and Electrical Engineer project professionals, 41(12.2%) were categorized as

quantity surveyors, 35 (10.4%) were categorized as architects project professionals project professionals and 24(7.2%) were categorized as other staff by project professionals. The findings on position category indicates that real estate projects are undertaken by qualified project professionals capable of responding to information sought on financial and contract management, project environment, organization capacity and construction cost overruns in real estate projects. Doloj (2012) established that position category by project professional is a contributing factor on the relationship between financial contract management and construction cost overruns in real estate projects.

### 4.3 Basic Tests for Statistical Assumptions of Regression Analysis

The study was based on a set of assumptions of regression analysis that must be met to ensure the data collected is appropriate for the statistical analysis. When these assumptions are violated the results of the analysis can be erroneous. The assumptions tested include normality, linearity, multi-collinearity and independence of errors.

#### Assumptions of Normality

An assessment of the normality of data is a prerequisite for many statistical tests because

normal data is an underlying assumption in parametric testing. The test for normality of data distribution was conducted on all the predictor variables, moderating variables using Kolmogorov-Smirnov test statistics (KS-test) and Shapiro-Wilk test (SW-test).

### 4.4 Negotiation Strategies and Construction Cost Overruns in Real Estate Projects

Negotiation strategies in this study is defined as negotiation methods such as structural technique, strategic technique, behavioral/diplomatic treaties, concession exchange and integrative technique. This was the third objective that the study sought to achieve; therefore, the participants were requested to give their opinions on their level of agreements or disagreements with the ten statements of Negotiation techniques on a Likert scale of 1-5 where Strongly agree (SA)=5, Agree(A)=4 Neutral(N)=3, Disagree (D)=2 and Strongly disagree. (SD)=1. The results were analyzed and presented using frequency, percentage, mean and standard deviation for each response in each item. The item mean as well as the standard deviation were also computed and presented alongside as provided in Table 3.

*Table 3:* Negotiation Strategies and Construction Cost Overruns in Real Estate Projects

ITEMS	SA	A	N	D	SD	Mean	Std. dev
I clearly define goals in negotiations	160(47.6%)	146(43.5%)	27(8.0%)	3(0.9%)	0(0.00%)	4.38	0.671
I set measurable targets in negotiations	137(40.8%)	176(52.4%)	21(6.2%)	2(0.6%)	0(0.00%)	4.33	0.620
I set clear expectations during negotiations	138(41.1%)	164(48.8%)	32(9.5%)	2(0.6%)	0(0.00%)	4.30	0.663
I uphold negotiated terms	136(40.5%)	169(50.3%)	29(8.6%)	2(0.6%)	0(0.00%)	4.31	0.650
I clarify roles and responsibilities during negotiations	147(43.8%)	162(48.2%)	24(7.1%)	3(0.9%)	0(0.00%)	4.35	0.652
I give adequate education and information on parties roles during negotiation	140(41.7%)	158(47.0%)	33(9.8)	5(1.5%)	0(0.00%)	4.29	0.702
I ensure proper identification of potential partners mutual interest during negotiation	144(42.9%)	161(47.9%)	27(8.0%)	4(1.2%)	0(0.00%)	4.32	0.673

I avail well developed operational plan of potential partner during negotiation	145(43.1%)	136(40.5%)	55(16.4%)	0(0.00%)	0(0.00%)	4.27	0.725
I organize consultative engagement at the beginning of a project	199(59.2%)	101(30.1%)	36(10.7%)	0(0.00%)	0(0.00%)	4.49	0.682
I avoid dictatorial approach in stakeholder engagement	190(56.6%)	106(31.5%)	36(10.7%)	4(1.2%)	0(0.00%)	4.43	0.730
<b>Composite mean &amp; composite standard deviation</b>						<b>4.35</b>	<b>0.673</b>

The results in Table 3 indicates that the composite mean and composite Standard deviation for the Negotiation strategies were 4.35 and 0.673 respectively; implying that using the Likert scale a majority of participants at least agreed (mean=4.35) that Negotiation strategies influences Construction Cost Overruns in Real Estate Projects. Similarly ten statements were developed to measure the extent to which Negotiation strategies influences Construction Cost Overruns in Real Estate Projects.

Statement (1) that ‘I clearly define goals in negotiation’ had a mean of 4.38 and a standard deviation of 0.671. This results indicate that out of 336 study participants, 160(47.6%) strongly agreed, 146(43.5%) agreed, 27(8%) were neutral and 3(0.9%) disagreed that they clearly define goals in negotiation. This results shows that the line statement mean score of 4.38 was higher than the composite mean of 4.35. The implication of this result to the study is that clearly defined goals in negotiation positively influence management of Construction Cost Overruns in Real Estate Projects. The study results supports finding by Famiyeh, et.al.,(2015) who found out that clearly defined goals in negotiation enhances Cost Overruns in Real Estate Projects.

Statement (2) that ‘I set out measurable targets in negotiation’ had a mean of 4.33 and a standard deviation of 0.620. This results indicate that out of 336 study participants, 137(40.8%) strongly agreed, 176(52.4%) agreed, 21(6.3%) were neutral and 2(0.6%) disagreed that they set out measurable targets in negotiation. This results shows that the line statement mean score of 4.33 was lower than the composite mean of 4.35. The implication of this result to the study is that there

is need to set out measurable targets in negotiation in order to positively influence management of Construction Cost Overruns in Real Estate Projects. The study results contradicts finding by Ahmed (2020) who found out that the use of key performance indicators (KPIs) which are also known as measurable targets; deployed to support the management of the outsourced maintenance was clearly designed to motivate the outsourcing contractor to achieve more financial benefits when meeting a defined set of KPIs while also delivering operating cost savings and other qualitative benefits to the outsourcing company.

Statement (3) that ‘I set clear expectations during negotiation’ had a mean of 4.30 and a standard deviation of 0.663. This results indicate that out of 336 study participants, 138(40.8%) strongly agreed, 164(48.8%) agreed, 32(9.5%) were neutral and 2(0.6%) disagreed that they set clear expectations during negotiation. This results shows that the line statement mean score of 4.30 was lower than the composite mean of 4.35. The implication of this result to the study is that there is need to set out clear expectations during negotiation in order to positively influence management of Construction management of Cost Overruns in Real Estate Projects. The study results supports finding by Kumar and Thakkar (2017) who found out that economic factors such as “Project delays,” “Unexpected incidents” and “Conflicts” have the highest influence on schedule and cost overrun.

Statement (4) that ‘I uphold negotiated terms’ had a mean of 4.31 and a standard deviation of 0.650. This results indicate that out of 336 study participants, 136(40.5%) strongly agreed,

169(50.3%) agreed, 29(8.6%) were neutral and 2(0.6%) disagreed that they uphold negotiated terms. This results shows that the line statement mean score of 4.31 was lower than the composite mean of 4.35. The implication of this result to the study is that there is need to uphold negotiated terms in order to positively influence management of Construction Cost Overruns in Real Estate Projects. The study results supports finding by Miller (2014) who found out that it is a common occurrence for contracts to undergo many revisions, often times quite severe, which cause costly hold-up problems such as renegotiation frictions and dampened incentives cost reducing investments. Therefore it is necessary to uphold negotiated terms for cost reductions.

Statement (5) that 'I clarify roles and responsibilities during negotiation' had a mean of 4.35 and a standard deviation of 0.652. This results indicate that out of 336 study participants, 147(43.8%) strongly agreed, 162(48.2%) agreed, 24(7.1%) were neutral and 3(0.9%) disagreed that they clarify roles and responsibilities during negotiation. This results shows that the line statement mean score of 4.35 was similar to the composite mean of 4.35. The implication of this result to the study is that clarifying roles and responsibilities during negotiation positively influence management of Construction Cost Overruns in Real Estate Projects. The study results supports finding by Hoezen, Voordijk and Dewulf (2012) who found out that complex construction project with critical events show that problems of understanding are caused by differences between the formal legal and the informal psychological contract of one of the parties involved.

Statement (6) that 'I give adequate education and information on parties roles during negotiation' had a mean of 4.29 and a standard deviation of 0.702. This results indicate that out of 336 study participants, 140(41.7%) strongly agreed, 158(47.0%) agreed, 33(9.8%) were neutral and 5(1.5%) disagreed that they give adequate education and information on parties roles during negotiation. This results shows that the line statement mean score of 4.29 was lower than the composite mean of 4.35. The implication of this

result to the study is that there is need to give adequate education and information on parties' roles during negotiation in order positively influence management of Construction Cost Overruns in Real Estate Projects. The study results also supports finding by Hoezen, Voordijk and Dewulf (2012) who further explain that cooperative working relationship as a result of complete information reduces cost overruns in large construction projects.

Statement (7) that 'I ensure proper identification of potential partners mutual interest during negotiation' had a mean of 4.32 and a standard deviation of 0.673. This results indicate that out of 336 study participants, 144(42.9%) strongly agreed, 161(47.9%) agreed, 27(8%) were neutral and 4(1.2%) disagreed that they ensure proper identification of potential partners mutual interest during negotiation. This results shows that the line statement mean score of 4.32 was lower than the composite mean of 4.35. The implication of this result to the study is that there is need to ensure proper identification of potential partner's mutual interest during negotiation in order positively influence management of Construction Cost Overruns in Real Estate Projects. Cheng and Li (2001) in their study found out that construction partnering has some critical factors such as mutual trust and open communication that should be embraced for success in construction projects.

Statement (8) that 'I avail well developed operational plan of potential partner during negotiation' had a mean of 4.27 and a standard deviation of 0.725. This results indicate that out of 336 study participants, 145(43.1%) strongly agreed, 136(40.5%) agreed and 55(16.4%) were neutral that they avail well developed operational plan of potential partner during negotiation. This results shows that the line statement mean score of 4.27 was lower than the composite mean of 4.35. The implication of this result to the study is that there is need to avail well developed operational plan of potential partner during negotiation in order positively influence management of Construction Cost Overruns in Real Estate Projects. The study results supports finding by Khan (1995) who found out that that some basic operational measures need to be put in

place to deal with the difficult and challenging problems of implementation, which would ensure more dependable and successful plan/policy/programme/project implementation.

Statement (9) that ‘I organize consultative engagement at the beginning of a project’ had a mean of 4.49 and a standard deviation of 0.682. This results indicate that out of 336 study participants, 199(59.2%) strongly agreed, 101 (30.1%) agreed and 36(10.7%) were neutral that they organize consultative engagement at the beginning of a project. This results shows that the line statement mean score of 4.49 was higher than the composite mean of 4.35. The implication of this result to the study is that organizing consultative engagement at the beginning of a project positively influence management of Construction Cost Overruns in Real Estate Projects. The study results supports finding Foster and Jonker (2005) who found that the dialogue of stakeholder engagement should be communication that is linked to mutual understanding as the basis of agreeable action. When this is done at the initial stages of the project then performance is assured.

Statement (10) that ‘I avoid dictatorial approach in stakeholder engagement’ had a mean of 4.43 and a standard deviation of 0.730. This results indicate that out of 336 study participants, 190(56.6%) strongly agreed, 106(31.5%) agreed,

36(10.7%) were neutral and 4(1.2%) disagreed that they avoid dictatorial approach in stakeholder engagement. This results shows that the line statement mean score of 4.43 was higher than the composite mean of 4.35. The implication of this result to the study is that avoiding dictatorial approach in stakeholder engagement positively influence management of Construction Cost Overruns in Real Estate Projects. The study results supports finding by Trushell, Clark and Agapiou (2016) who found out that mediations in construction failed because of ignorance, intransigence and over-confidence of the parties.

Barriers to greater use of mediation in construction disputes were identified as the lack of skilled, experienced mediators, the continued popularity of adjudication and both lawyer and party resistance.

#### 4.5 Correlation analysis of Negotiation Strategies and Construction Cost Overruns in Real Estate Projects

The study sought to examine the relationship between Negotiation strategies and construction cost overruns in real estate projects. Pearson correlation coefficient was used to test the relationship between Negotiation strategies and construction cost overruns in real estate projects at 95% level of confidence. The correlations results obtained are shown in Table 4.

**Table 4:** Correlations of Negotiation Strategies and Construction Cost Overruns in Real Estate Projects

Negotiation techniques statements		Construction cost overruns in real estate projects
1. I clearly define goals in negotiation	Pearson correlation	0.011*
	sig. (2-tailed)	0.843
	n	336
2. I set out measurable targets in negotiation	Pearson correlation	0.018*
	sig. (2-tailed)	0.748
	n	336
3. I set clear expectations during negotiation	Pearson correlation	0.038*
	sig. (2-tailed)	0.490
	n	336
4. I uphold negotiated terms	Pearson correlation	0.142*
	sig. (2-tailed)	0.010
	n	336
5. I clarify roles and responsibilities during negotiation	Pearson correlation	0.261*
	sig. (2-tailed)	0.000
	n	336
6. I give adequate education and information on parties roles during negotiation	Pearson correlation	0.227*
	sig. (2-tailed)	0.000
	n	336

7. I ensure proper identification of potential partners mutual interest during negotiation	Pearson correlation	0.172*
	sig. (2-tailed)	0.002
	n	336
8. I avail well developed operational plan of potential partner during negotiation	Pearson correlation	0.287*
	sig. (2-tailed)	0.000
	n	336
9. I organize consultative engagement at the beginning of a project	Pearson correlation	0.216*
	sig. (2-tailed)	0.000
	n	336
10. I avoid dictatorial approach in stakeholder engagement	Pearson correlation	0.277*
	sig. (2-tailed)	0.000
	n	336
Negotiation Strategies (overall correlation)	Pearson correlation	0.286*
	Sig.(2-tailed)	0.000
	n	336

\*Correlation is significant at 0.05 level (2-tailed)

To test the extent of the relationship between Negotiation strategies and reduction of construction cost overruns in real estate projects; several characteristics of Negotiation strategies and reduction of construction cost overruns in real estate projects were analyzed based on the following hypothesis; Ho: There is no significant relationship between Negotiation strategies and reduction of construction cost overruns in real estate projects. The corresponding mathematical model for the hypothesis was identified as follows: reduction of construction cost overruns in real estate projects = f (Negotiation strategies).

In order to determine the correlation between Negotiation strategies and construction cost overruns, Pearson correlation coefficient was run on the scores of each scale. The total scores of the scales were computed as a summation of the individual scores on each item by the respondent at 95% level of confidence. The study found a positive overall correlation ( $r=0.286$ ) which was statistically significant as  $P < 0.05$  ( $p=0.000$ ) between Negotiation strategies and construction cost overruns in real estate projects ;implying that there is a significant relationship between Negotiation Strategies and construction cost overruns in real estate projects leading to rejection of the null hypothesis (Ho : There is no significant relationship Negotiation strategies and construction cost overruns in real estate projects) and acceptance of the alternative hypothesis, and hence the research findings conclude that there is

a significant relationship between Negotiation strategies and construction cost overruns in real estate projects. The study results supports finding by Sambasivan, Deepak, Salim and Ponniah (2015) who found that cost overruns in construction projects can be explained by consultant-related and material-related factors; disputes and arbitration can be explained through consultant-related factors whereas litigation can be explained by client-related factors; therefore implying that there is a significant relationship between negotiation techniques and cost overruns.

#### 4.6 Regression Analysis of Negotiation Strategies on Construction Cost Overruns in Real Estate Projects

Simple linear regression was adopted to investigate how Negotiation strategies influence the construction cost overruns in real estate projects. It was necessary to get the views of the participants on the influence of Negotiation strategies on construction cost overruns in real estate projects. The rational of using the simple regression model was to establish how Negotiation strategies as a predictor significantly or insignificantly predicted the construction cost overruns in real estate projects.

**4.6.1 Model Summary of Negotiation Strategies on Construction Cost Overruns in Real Estate Projects**

The model summary sought to determine how Negotiation strategies is a predictor that

significantly or insignificantly predicted construction cost overruns in real estate projects. The regression model summary results are presented in Table 5.

**Table 5:** Regression Model Summary table of Negotiation Strategies and Construction Cost Overruns in Real Estate Projects

Model Summary				
Model	R	R Square	Adjusted R Square	Std. Error of the Estimate
1	0.286 <sup>a</sup>	0.082	0.079	3.50432
a. Predictors: (Constant), Negotiation techniques				

The model summary results from Table 5 suggest that there is a positive correlation(R=0.286) between Negotiation strategies and construction cost overruns in real estate projects and those predicted by the regression model. In addition, 8.2% of the variation in the reduction of construction cost overruns in real estate projects is explained by Negotiation strategies. The results are consistent with the findings of a study Sambasivan, et. al., (2015) who found out that negotiation techniques contribute to the reduction of cost overruns in Tanzanian construction industry.

**4.6.2 ANOVA of Negotiation Strategies and Construction Cost Overruns in Real Estate Projects**

The study sought to establish if the regression model is best fit for predicting construction cost overruns in real estate projects after use of Negotiation strategies. The ANOVA results are presented in Table 6.

**Table 6:** An ANOVA of the Regression of Negotiation Strategies and Construction Cost Overruns in Real Estate Projects

Model		Sum of Squares	df	Mean Square	F	Sig.
1	Regression	364.386	1	364.396	29.673	0.000 <sup>b</sup>
	Residual	4101.602	334	12.280		
	Total	4465.988	335			
a. Dependent Variable: <b>construction cost overruns in real estate projects</b>						
b. Predictors: (Constant), Negotiation strategies						

The study sought to establish if the regression model is best fit for predicting construction cost overruns in real estate projects after use of Negotiation strategies. The ANOVA results indicated that (F-statistics (1,334) =29.673 is significant since the P -value 0.000< 0.05 implying that the predictor co-efficient is at least not equal to zero. and hence the regression model results in significantly better prediction of construction cost overruns in real estate projects. The results are consistent with the findings of a

study by Steininger, Groth and Weber (2019) who found out that one cause of cost overruns in infrastructure projects was as a result of disagreements on parties' interest; this could be mitigated through application of Negotiation strategies.

4.6.3 Coefficients for Regression of Negotiation Strategies and Construction Cost Overruns in Real Estate Projects

Construction cost overruns in real estate projects. The regression coefficients results are presented in Table 7.

The study sought to establish whether there was influence of Negotiation strategies and

Table 7: Coefficients for the Regression of Negotiation Strategies and Construction Cost Overruns in Real Estate Projects

Coefficients						
Model		Unstandardized Coefficients		Standardized Coefficients	t	Sig.
		B	Std. Error	Beta		
1	(Constant)	32.450	2.097		15.472	0.000
	Negotiation strategies	0.262	0.048	0.286	5.447	0.000

The study sought to establish whether there was influence of Negotiation strategies on construction cost overruns in real estate projects. The simple linear regression coefficients result indicated that there was significant influence of Negotiation strategies on construction cost overruns in real estate projects. It was therefore concluded that Negotiation strategies and construction cost overruns in real estate projects were positively and linearly related. Lu, Zhang and Bai (2016) found that the learning ability on Negotiation strategies guarantees cost reduction through contribution to accelerating construction claim negotiations in the win-win situation.

This therefore indicate that Negotiation strategies and construction cost overruns in real estate projects were positively and linearly related.

V. CONCLUSIONS AND RECOMMENDATIONS

The research objective was to examine the extent to which Negotiation Strategies influence Construction Cost Overruns in Real Estate Projects. The simple linear regression coefficients as well as the Pearson correlation results indicated that there was significant influence of Negotiation Strategies on Construction Cost Overruns in Real Estate Projects. The small p-values; implied that there was a significant influence of Negotiation Strategies on Construction Cost Overruns in Real Estate Projects.

Considering the study findings and conclusions, the following recommendations were made: Project professionals and other relevant real estate project stakeholders should ensure measurable targets in negotiation and proper identification of potential parties' mutual interest during negotiation to positively manage construction cost overruns in real estate projects.

VI. LIMITATIONS OF THE STUDY

The study involved project professionals in interviews, these are busy people and therefore adequate time was required to schedule meetings with them. The challenge was mitigated through allocating sufficient time for appointments and increased use of online technology for both communication and data collection. The period when the proposed study was envisioned to take place was marred with great uncertainty of events due to corona virus pandemic but this was mitigated through flexibility of adapting the most effective and functional technology to reach the proposed respondents.

REFERENCES

- Ahady, S., Gupta, S. and Malik, R.K. (2017) A critical review of the causes of cost overrun in construction industries of developing countries. International Research Journal of Engineering and Technology, 4(3), pp.2550-2558.

2. Aibinu Ajibade. (2009). Avoiding and Mitigating Delay and Disruption Claims Conflict: Role of Precontract Negotiation. *Journal of Legal Affairs and Dispute Resolution in Engineering and Construction*. 1.10.1061/(ASCE)1943-4162(2009)1:1(47).
3. Alias Z, Zawawi E.M.A, Yusof K, Aris N.M (2014). Determining critical success factors of project management practice: A conceptual framework. *Procedia: Social and Behavioral Sciences*, 153: 61–69.
4. Brooke J., (2013). "SUS-A quick and dirty usability scale (in Usability Evaluation in Industry)" London publisher
5. Cantarelli, C., Flyvbjerg, B., Molin, E.J.E. & van Wee, B. (2010) "Cost Overruns in Large-Scale Transportation Infrastructure Projects: Explanations and their Theoretical Embeddedness". *European Journal of Transport and Infrastructure Research*, 10(1), 5–18.
6. Cheng Eddie W. L. and Li Heng (2001). Development of a conceptual model of construction partnering. First published: 20 December 2001. <https://doi.org/10.1046/j.1365-232x.2001.00210.x>.
7. Cheung, Chow & Yiu (2009). "Effects of Capital Flow on the Equity and Housing Markets in Hong Kong", <https://doi.org/10.1111/1468-0106.12233>.
8. Clark B. & Agapiou A. (2016) Construction mediation in Scotland : an investigation into attitudes and experiences of mediation practitioners. *International Journal of Law in the Built Environment*, 8 (2). pp. 101-122. ISSN 1756-1450.
9. Cunningham, T. (2017), "Cost Control During the Pre-Contract Stage of a Building Project" – An Introduction, Arrow, Dublin Institute of Technology, online: <http://arrow.dit.ie/beschreoth/49/>.
10. De Vaus, D. (2001). "Research Design in Social Research". London: SAGE Publications Ltd.
11. Doloi, H. (2012). "Analyzing Factors Affecting Delays in Indian Construction Projects." *International Journal Project Management*, 30(4), 479–489.
12. Doloi, H. (2013). "Cost Overruns and Failure in Project Management: Understanding the Roles of Key Stakeholders in Construction Projects". *Journal of Construction Engineering and Management*, 139, 267–79.
13. Durdyev, S., Omarov, M. and Ismail, S. (2017). SWOT Analysis of the Cambodian construction industry within the ASEAN economic community, Proceedings of the 28th International Business Information Management Association Conference, Seville, November 9-10.
14. Famiyeh, S., Amoatey C. T., Ameyaw Y. A., & Adaku, E. (2015). Analysing delay causes and effects in Ghanaian state housing construction projects. *International Journal of Managing Projects in Business*, 8(1), 198-214. doi:10.1109/IJMPB-04-2014-0035.
15. Foster David & Jonker Jan. (2005). Stakeholder Relationships: The Dialogue of Engagement. *Corporate Governance*. 5. 51-57. 10.1108/14720700510630059.
16. Hoezen Mieke, Voordijk Hans & Dewulf Geert. (2012). Contracting dynamics in the competitive dialogue procedure. *Built Environment Project and Asset Management*. 2. 6-24. 10.1108/20441241211235017.
17. Kang BG, Elbashier M, Tang L, Jin R. and Tang S, (2018). "Competitive tendering for Construction Projects in Sudan". *Journal of Fundamental and Applied Sciences* 10 (3S), 828-835
18. Khan M. Adil (1995). Sustainable development: The key concepts, issues and implications. Keynote paper given at the international sustainable development research conference, 27–29 march 1995, Manchester, UK.
19. Khodeir & Ghandour, (2018). "Examining the Role of Value Management in Controlling Cost Overrun (Application on Residential Construction Projects in Egypt)".
20. Kothari, C. R. (2004), "Research Methodology-Methods and Techniques". 2nd revised edition. Published by New age international publisher. Page 32. Kotval and Mullin.
21. Krejcie, R.V., & Morgan, D.W. (1970). "Determining Sample Size for Research Activities". *Educational and Psychological Measurement*, 30, 607-610.
22. Kumar, S. and Thakkar, J.J. (2017), "Schedule and cost overrun analysis for R&D projects

- using ANP and system dynamics", *International Journal of Quality & Reliability Management*, Vol. 34 No. 9, pp. 1551-1567. <https://doi.org/10.1108/IJQRM-04-2016-0050>.
23. Lerner, A. P. (1968) "Microeconomic Theory", Printed in *Perspectives in Economics*, edited by Brown, Neuberger and Palmatier (Preliminary edition), p. 30.
  24. Lind & Brunen, F., (2015). "Explaining Cost Overruns in Infrastructure Projects: A New Framework with Applications to Sweden". *Construction Management Economics*. 33 (7), 554–568.
  25. Lu W., Zhang L. & Bai, F. (2016). "Bilateral learning model in construction claim negotiations", *Engineering, Construction and Architectural Management*, Vol. 23 No. 4, pp. 448-463. <https://doi.org/10.1108/ECAM-04-2014-0062>.
  26. Miller TR (2014) Constructing sustainability science: emerging perspectives and research trajectories. *Sustain Sci* 8(2):279–293.
  27. Mugenda, O. M. & Mugenda, A. G. (2003). "Research methods: Quantitative and qualitative Approaches". Nairobi: African Centre for Technology Studies.
  28. Ndihi, L.W & Noor (2019). Effect of Post Tender Negotiations on Performance of Commercial State Corporations in Kenya, *American Based Research Journal*, 8(10), 12-21.
  29. Niazi G. A. & Painting N. (2017). "Significant Factors Causing Cost Overruns in the Construction Industry in Afghanistan" *Procedia Engineering* 182 510.
  30. Pannebakker (2013). "Offer and Acceptance and the Dynamics of Negotiations: Arguments for Contract Theory from Negotiation Studies".
  31. Rosenfed (2013). "Root-Cause Analysis of Construction- Cost Overruns", *Journal of Construction Engineering and Management*, 10(1), pp.1-10. Richard O. Asiedu and Hans W. Alfen 22.
  32. Sambasivan M., Deepak T.J., Salim Ali & Ponniah V.. (2015). Analysis of delays in Tanzanian construction industry: Transaction cost economics (TCE) and structural equation modeling (SEM) approach. *Engineering, Construction and Architectural Management*. 24. 308-325. [10.1108/ECAM-09-2015-0145](https://doi.org/10.1108/ECAM-09-2015-0145).
  33. Steininger B., Groth M. & Weber B.. (2019). Cost overruns and delays in infrastructure projects: the case of Stuttgart 21. *Journal of Property Investment & Finance*. ahead-of-print. [10.1108/JPIF-11-2019-0144](https://doi.org/10.1108/JPIF-11-2019-0144).
  34. Wachowicz T., Kersten G. & Roszkowska E. (2018). "Can the Holistic Preference Elicitation be used to determine an Accurate Negotiation Offer Scoring System?" *A Comparison of Direct Rating and Utastar Techniques*. *Lecture Notes Bus Information Process* 293:202–214.
  35. Zillante, Read & Seiler (2019) "Using Prospect Theory to Better Understand the Impact of Uncertainty on Real Estate Negotiations".

*This page is intentionally left blank*



Scan to know paper details and  
author's profile

# The Manufacturing Method of the Field Driven Generator

*Katsuo Sakai*

## ABSTRACT

Today, the sun is a very useful energy source because it continuously radiates energy. An electron is radiating energy continuously too. A new electrostatic generating method using this electron's electric field energy as a driving force of charge carriers was invented, and its success was presented on ESA 2017 and ESA 2019 by a bench model. This new electrostatic generator was realized by asymmetric electrostatic force, which is a new phenomenon. The electric output of the bench model was only a few ten micro-watt. Then, it is confirmed by a simulation that the electric output becomes kilo-watt when parts size is reduced to 1/100. However, the simulated machine can't be manufactured actually because it's a lot of charge carriers are very small and complex. But this problem has been solved by a new shape of the charge carrier and its new manufacturing method.

*Keywords:* "Asymmetric electrostatic force", "Field driven generator", "Asymmetric shape charge carrier", "Electret", "Long charge carrier".

*Classification:* DDC Code: 621.042 LCC Code: TJ163.2

*Language:* English



LJP Copyright ID: 392953

Print ISSN: 2631-8474

Online ISSN: 2631-8482

London Journal of Engineering Research

Volume 22 | Issue 4 | Compilation 1.0



# The Manufacturing Method of the Field Driven Generator

Katsuo Sakai

## ABSTRACT

Today, the sun is a very useful energy source because it continuously radiates energy. An electron is radiating energy continuously too. A new electrostatic generating method using this electron's electric field energy as a driving force of charge carriers was invented, and its success was presented on ESA 2017 and ESA 2019 by a bench model. This new electrostatic generator was realized by asymmetric electrostatic force, which is a new phenomenon. The electric output of the bench model was only a few ten micro-watt. Then, it is confirmed by a simulation that the electric output becomes kilo-watt when parts size is reduced to 1/100. However, the simulated machine can't actually be manufactured because the charge carriers are very small and complex. But this problem has been solved by a new shape of the charge carrier and its new manufacturing method.

**Keywords:** "Asymmetric electrostatic force", "Field driven generator", "Asymmetric shape charge carrier", "Electret", "Long charge carrier".

**Author:** Electrostatic generator Laboratory Yokohama Japan.

## I. INTRODUCTION

### 1.1 Two very useful energy sources: Sun and Electron

Today the most useful energy source to solve the environment problem is the Sun, because it is radiating a huge amount of energy around it continuously as shown in figure 1. Like the sun, an electron too is radiating an energy around it continuously. Of course, the radiated energy from an electron is very little. However, the number of electrons in our world is huge. An electret keeps an electron on its surface for a very long time (100 years). Therefore, if a new electrostatic generator is driven by an electret only, this one will solve the environment problem perfectly. Because it does not produce CO<sub>2</sub>, it is safe, it produces electric energy all time everywhere, it has a long life time and its cost is low.

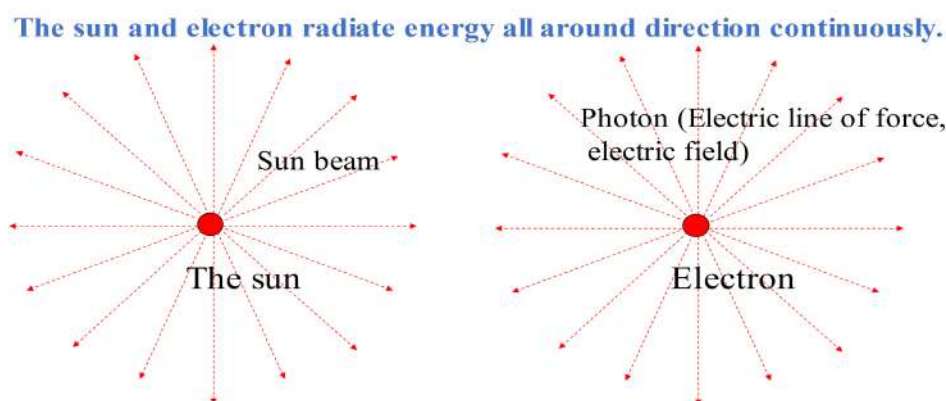

Fig. 1: There are two big renewable energy: the sun (used) and an electron (not used)

1.2 Asymmetric electrostatic force

$$f=qE \tag{1}$$

For a long time, the electrostatic force has been calculated by the well-known Coulomb's Formula (1).

It is apparent from this formula that the magnitude of this electrostatic force does not change when the direction of the electric field turns over as shown in Figure 2.

where f: Electrostatic force that acts on a point charge.

q: Quantity of a point charge.

E: Intensity of the electric field in which a point charge is placed.

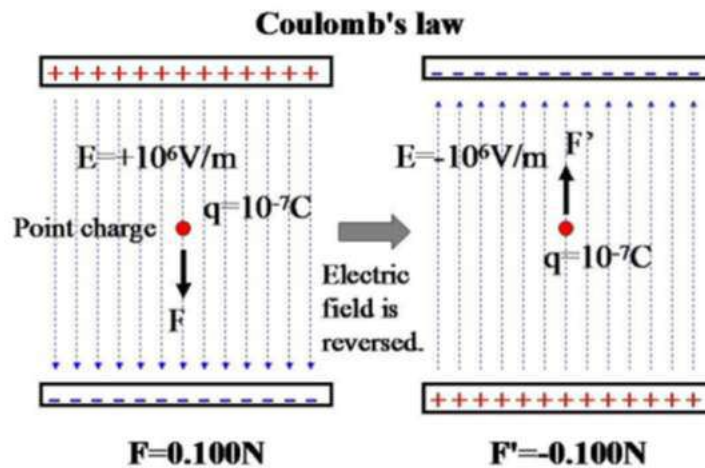

Fig. 2: The well-known Coulomb's Formula

The application of this formula is limited to point charges and sphere-shaped charge carriers [1].

A new electrostatic generator driven by only an electric field using Coulomb's law was tried for several years. Many different ideas were tested by a simulation and simple experiment.

However, a solution was not found, but a very useful phenomenon was found in those simulations by chance.

A new electrostatic generator driven by this new phenomenon was invented.

The electrostatic force that acts on an asymmetric charged conductor changes largely when the direction of the electric field reverses, as shown in Figure 3.

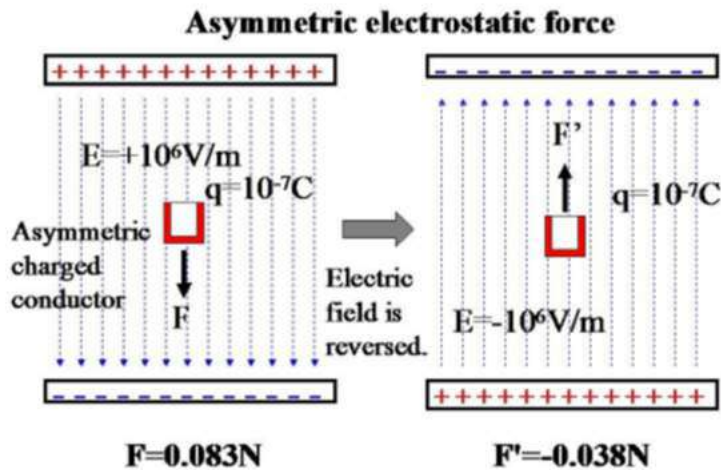

Fig. 3: Electrostatic force that acts on charged box conductor (Asymmetric electrostatic force) acts on this charge.

This new phenomenon was named asymmetric electrostatic force [2],[3],[4],[5],[6],[7],[8]. The left side electric field of Figure 3 was named a forward electric field, and the right side electric field was named a backward electric field.

### 1.3 Basic theory of the new electrostatic generator

The basic theory of an electrostatic generator is defined by lifting the charge to a high potential by

mechanical force against the electric force that It is impossible for the mechanical force to carry the charge directly. Therefore, the charge is packed into a suitable body. We call this body the charge carrier.

A basic unit of the new electrostatic generator that is driven by asymmetric electrostatic force is concretely shown in Figure 4.

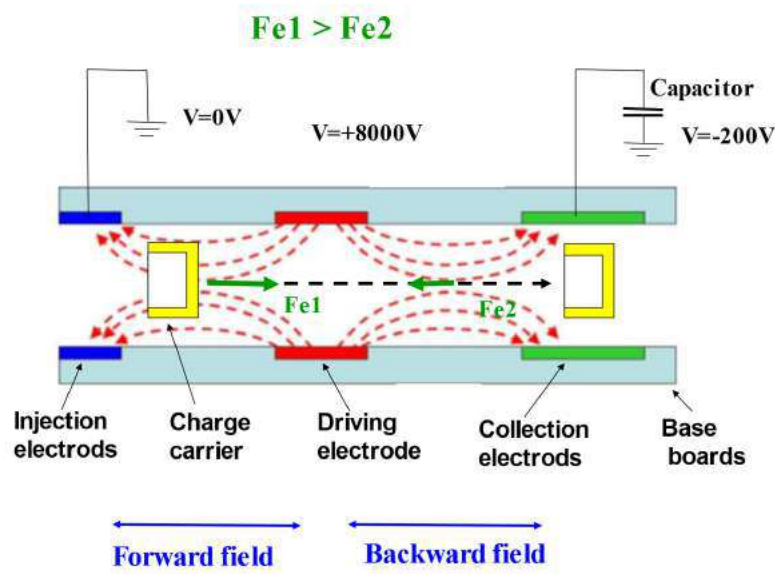

Fig. 4: Schematic layout of one unit of the new electrostatic generator

This generator mainly consists of a charge injection electrode, driving electrode, charge collection electrode, and charge carrier.

A positive high voltage was applied to the driving electrode. The injection electrode was grounded. The collection electrodes were kept at a negative low voltage.

As a result, the driving electrode and the injection electrode produced a forward electric field for a negative charge between them.

The driving electrode and the collection electrode produced a backward electric field for a negative charge between them.

A gutter-shaped conductor was used as a charge carrier that carries a negative charge (electron) from the injection electrode to the collection electrode through the driving electrode.

The asymmetric electrostatic phenomenon produces a large electrostatic force  $F_{e1}$  in the

forward electric field and a weak electrostatic force  $F_{e2}$  in the backward electric field.

Therefore, the charge carrier gains large kinetic energy in the forward electric field. Then, it loses some of its kinetic energy in the backward electric field.

As a result, the charge carrier maintains extra kinetic energy when it arrives at the collection electrode.

The carried charge can be lifted to a higher potential by this extra energy.

This is the principle of the electric field-driven generator.

#### 1.4 Experimental equipment of the electric field driven generator

Figure 5 shows the front view, Figure 6 shows a plane view and Figure 7 shows a photograph of the experimental equipment.

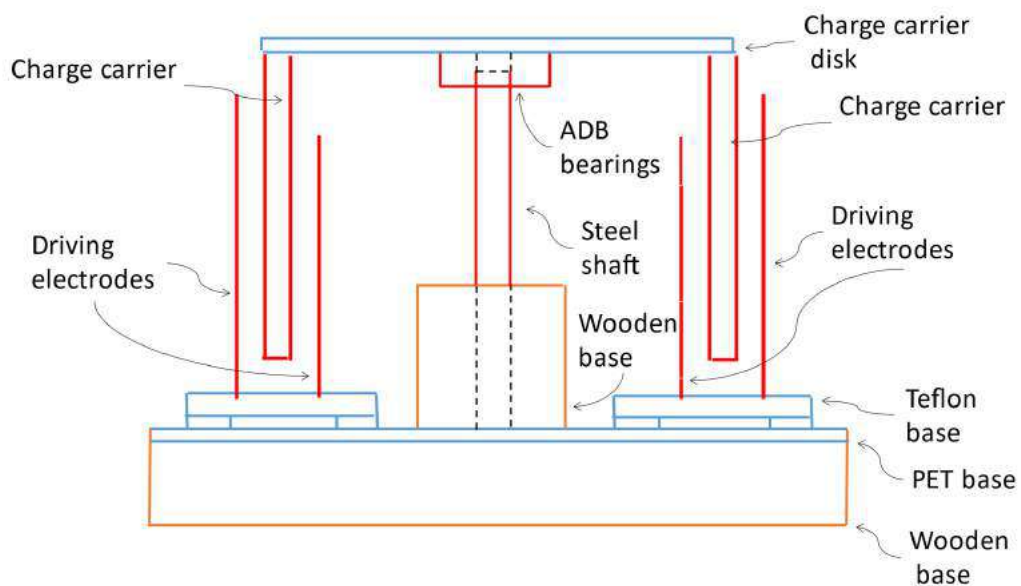

Fig. 5: Front view of the experimental equipment of the electric field driven generator.

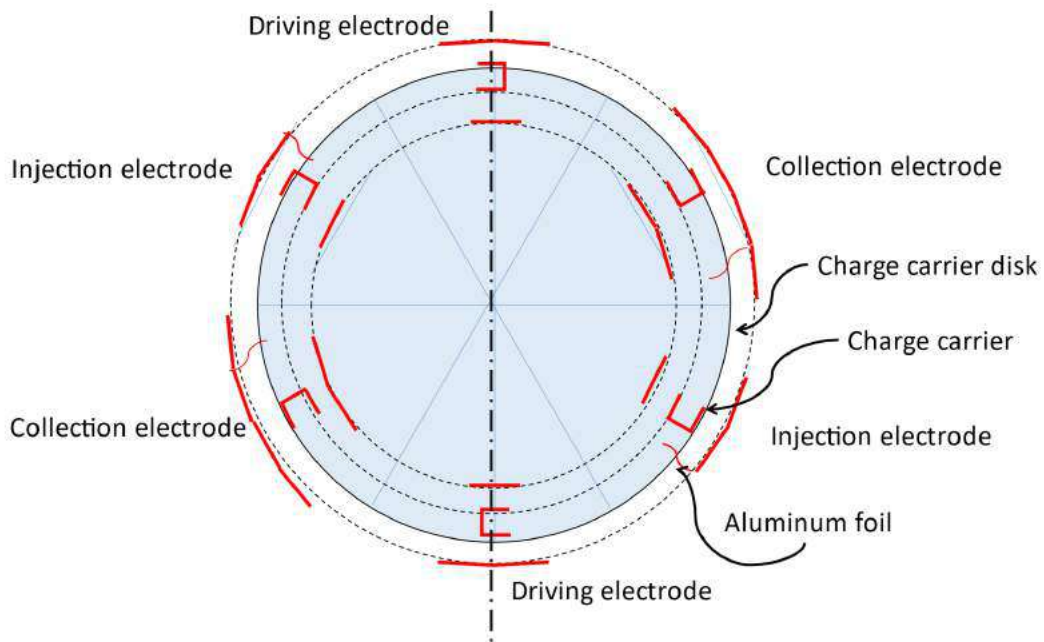

Fig. 6: Plane view of the experimental equipment of the electric field driven generator

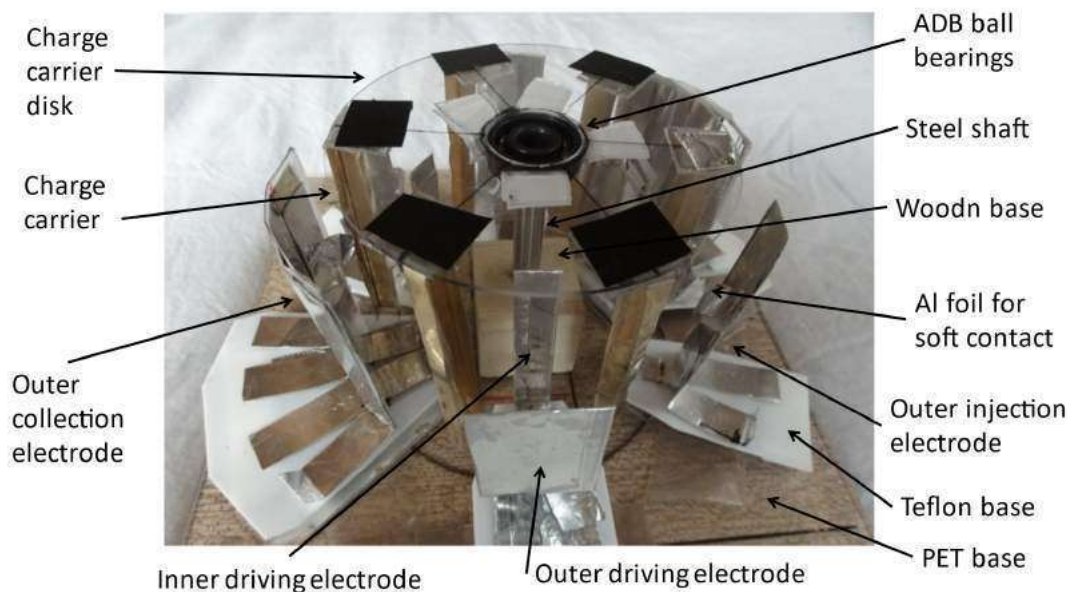

Fig. 7: Photograph of the main part of the electric field driven generator

This equipment mainly consists of a charge injection electrode, a driving electrode, a charge collection electrode, and a charge carrier disk that has six charge carriers.

The charge carrier disk is a 0.5-mm thick PET plate with a diameter of 95 mm. ADB (autonomous decentralized bearing) bearings were fixed on the center of the disk.

The six charge carriers were placed at 60 degrees intervals, as shown in Figure 6.

The two charge injection electrodes, the two driving electrodes, and the two charge collection electrodes were placed on the main PET base plate at 60 degrees intervals, as shown in Figure 6.

The injection electrode was always grounded, the driving electrode was connected to a high voltage power supply, and the surface potential of the collection capacitor was measured by a surface potential meter.

The collection electrodes could perform semi-Faraday gauges. When the charge carrier was connected to the collection electrode by the aluminum foil, more than 90% charge on the charge carrier was transferred to the collection electrode (simulation result).

A surface potential meter (SHISHIDO ELECTROSTATIC: STATIRON-DZ 3) was used to measure the surface potential of the collection capacitor.

*1.4 Experimental result of the electric field-driven generator*

When -7kV was applied to the driving electrode, the charge carrier disk start to rotate automatically slowly. Then the rotation speed

increase gradually, and it becomes constant finally. <https://youtu.be/yNwOOTq3N-o>. You can see this movie, when you click here.

This result indicates that the charge carrier disk can rotate endlessly by the electrostatic force against the air resistance force and kinetic friction force.

When the charge carrier continues to rotate, the surface potential of the collection electrode capacitor becomes higher in the negative direction. These results mean that this experimental equipment continued to endlessly generate electric power.

Figure 8 shows the surface potential change of the collection electrode capacitor when the driving voltage was 7.0 kV.

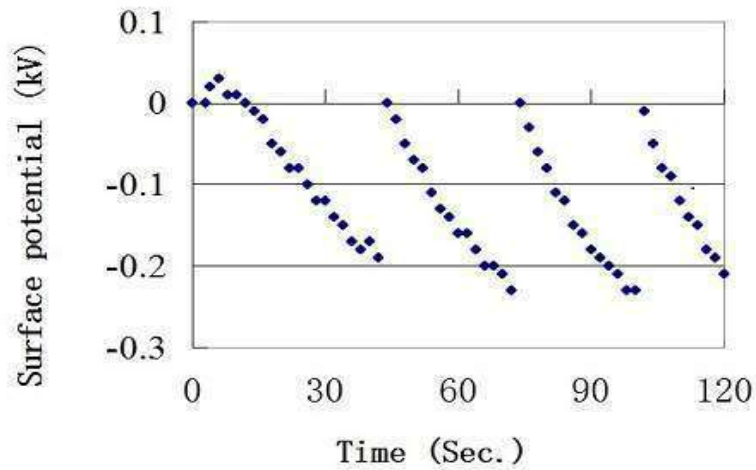

*Fig. 8:* The surface potential change of the capacitor of the collection electrode for the rotation time of the charge carrier disk

This result was presented in ESA 2017 [9], [10], and an improved result was presented in ESA 2019 [11] using the new charging method shown in Figure 9.

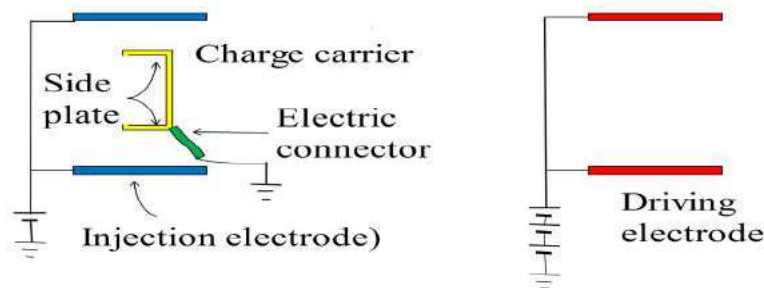

*Fig. 9:* The improved charge injection method

In Figure 9, the upper and lower side plates of the charge carrier and the injection electrode temporarily produce two capacitors. Therefore, many injection charges (electrons) are injected into the side plates from the ground through the electric connector.

The experiment of the new electrostatic generator succeeded many times after ESA2019. However, the success rate was not 100%. Therefore, the reason was researched and finally it became apparent that the result depended on the

difference between the simulation and the real experiment [12], [13].

Any way, its electric output is only a few tens microwatt now.

### 1.5 Increasing Method of the electric output

#### 1.5.1 Structure of the commercial machine

The experimental machine explained former has a big useless space under the charge carrier disk. Therefore, a commercial machine must lay the charge carrier down as shown in Fig.10.

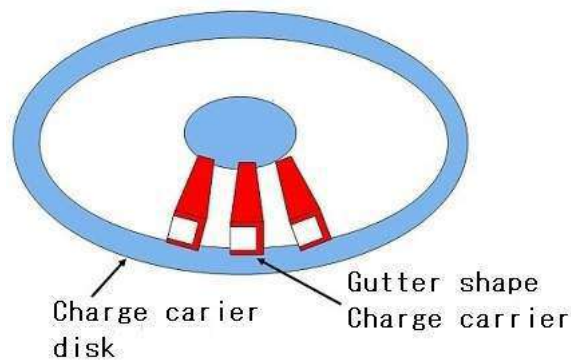

Fig. 10: Horizontally placed gutter shape charge carrier on the charge carrier disk

The injection electrode and the driving electrode on the experimental machine are changed to the injection electret and the driving electret on the commercial machine.

And also the injection electret, the driving electret and the collection electrode must be laid down too. They are placed face to face on back side of the upper electrodes disk and on surface side of the lower electrodes disk as shown in Fig.11.

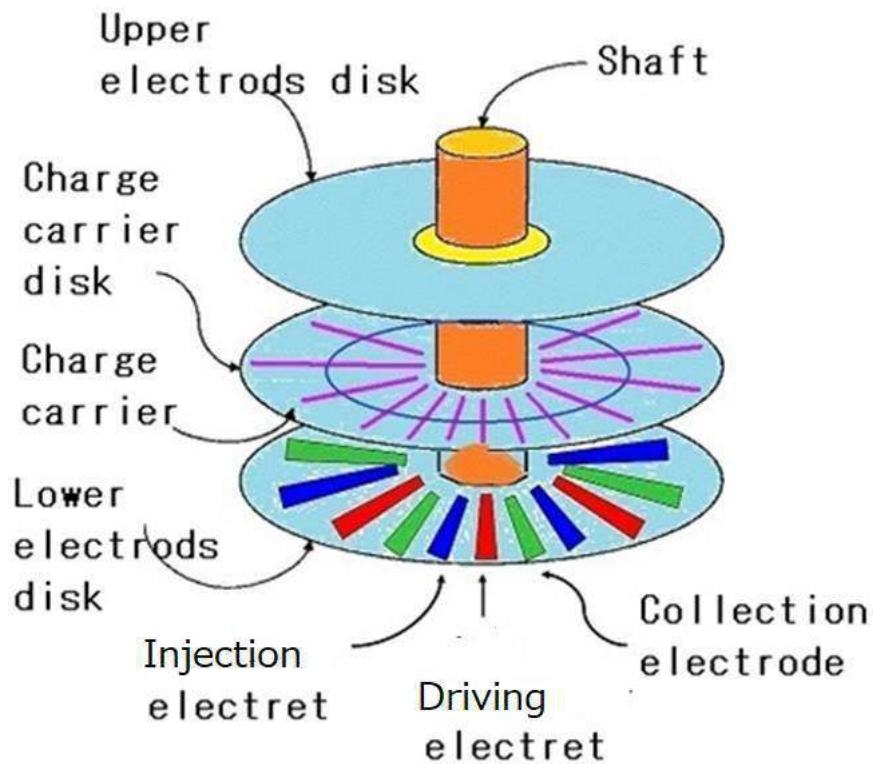

Fig. 11: One set of the new electrostatic generator consists of three disks and a center shaft

If the size of the charge carrier is 5\*5\*50mm like as the experimental machine, the radius of the disks become 90mm, and distance between the upper electrodes disk and the lower electrodes disk becomes 15mm.

This consist is named as 1 set. The size of 1 set become about same as CD cassette.

For high electric power, this set must be piled up as shown as Fig.12.

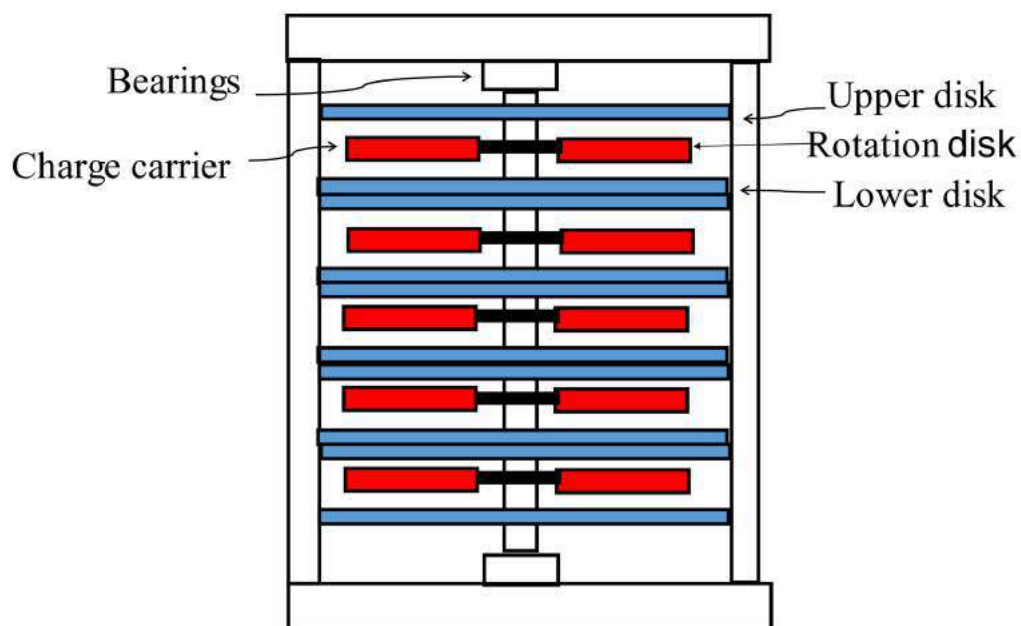

Fig. 12: An example of a commercial machine structure consists of five sets

The upper electrodes disk and the lower electrodes disk are fixed to main body.

The charge carrier disk is fixed to center pole shaft and rotates with it. Fig.12 shows five sets piling structure. However, many sets can be piled on one ball bearings, because the weight of the charge carrier is very light (10g).

The rotation speed of the charge carrier disk of the experimental machine is about 100 rpm. However if air resistance that acts on the rotate charge carrier becomes zero by vacuum condition of the commercial machine, it will become several thousand rpm.

And if the ball bearings rotation is replaced of magnetic levitation rotation, the rotation speed will become several ten thousand rpm. As a result, very big electric power will be realized.

*1.5.2. The methods that can increase the electrical output to one million times High speed rotation of the charge carrier disk*

The rotation speed of the charge carrier disk of the bench model is about 100 rpm. However, The maximum rotation speed of the ADB ball bearings is 30,000 rpm. Therefore, when the

rotation speed of the charge carrier disk become 10,000 rpm, the collected charge volume per seconds, namely a current becomes 100 times.

*Increasing the charge density of the charge carrier*

When the charge carrier enters between the upper and lower charge injection electret, two air capacitors are produced temporally between the injection electret and the side plane plate of the gutter shape charge carrier.

At this time, the charge carrier is earthed. As a result, some charge is injected into the charge carrier. The polarity of this charge is reversal to the polarity of the charge on the injection electret.

The injected charge density is in direct proportion to the charge density of the injection electret and inverse proportion to the distance between the injection electret and the side plane plate of the charge carrier.

Now this distance is 7.5mm, namely 7500  $\mu\text{m}$ . Therefore, when this distance is reduced to 75  $\mu\text{m}$  as shown in Fig.13 (2), the injected charge density increases to 100 times.

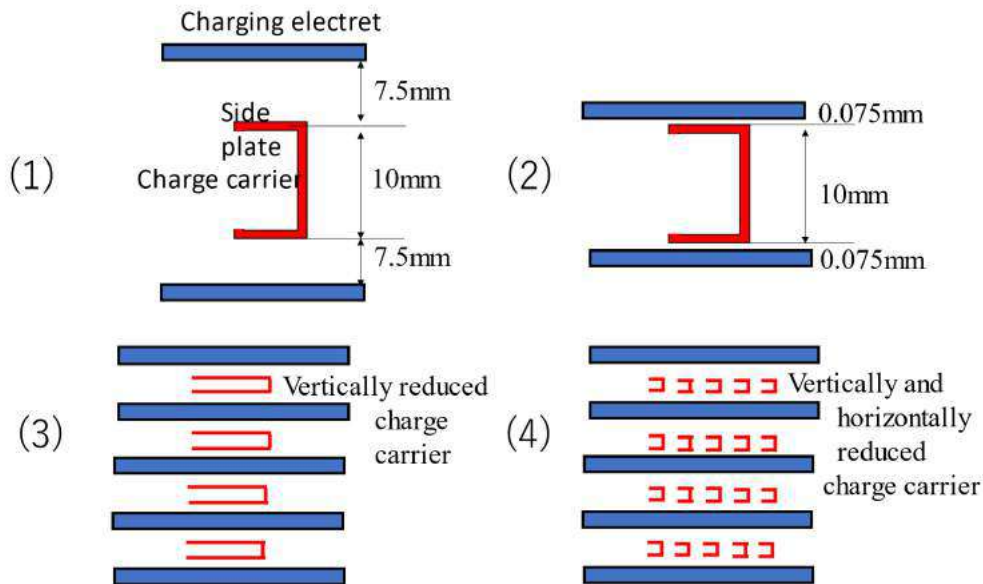

Fig. 13: Charge carrier downsizing steps

As a result, the collected charge volume per second, namely a current becomes 100 times.

*Method of increasing volume charge density*

The height of the charge carrier was not related with the injection charge density. Therefore, the

total volume charge of the all charge carriers become 100 times when the height is reduced from 10mm to 0.1 mm as shown Fig.13 (3).

However, width of the vertical reduced charge carrier becomes too long. Asymmetric electrostatic force can not pull this charge carrier. Therefore, the width must be reduced to 1/100 as shown in Fig.13 (4). As a result, total charge volume of the all charge carrier in the equipment becomes 100 times. Namely, the volume charge density becomes 100 times.

If multiply by those three methods, the electric output becomes  $100 \times 100 \times 100 = 1,000,000$  times.

### 1.5.3 Simulation of the electric output increasing methods

Then the electric output of the field driven generator was simulated by finite difference method when the part size is reduced to 1/100. On the electrode disk, the size reduced injection electrets, the driving electrets and the collection electrodes are placed as shown in Fig.14.

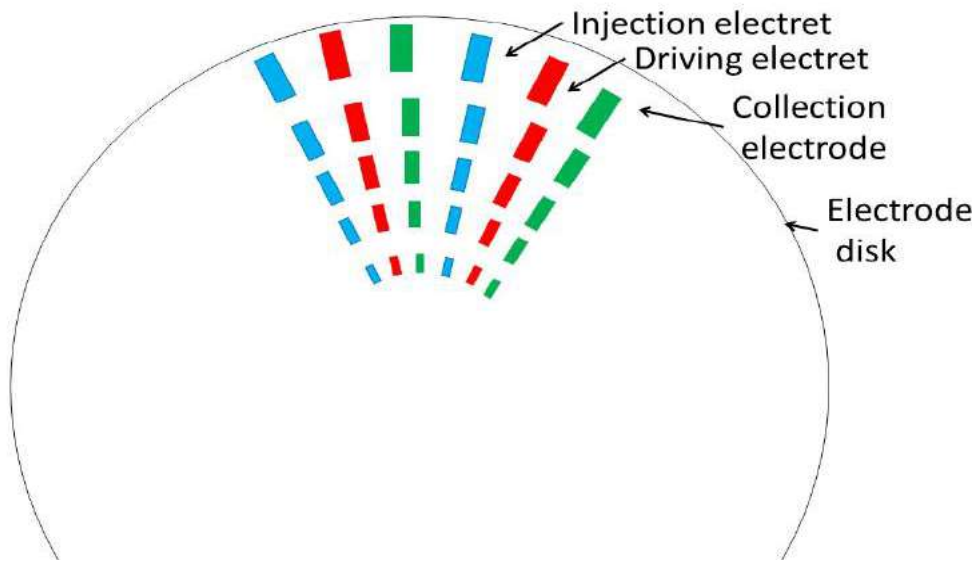

Fig. 14: Plane view of the electrode disk in that the three parts is reduced to 1/100.

And on the charge carrier disk, the charge carriers are placed radially as shown in Fig.15.

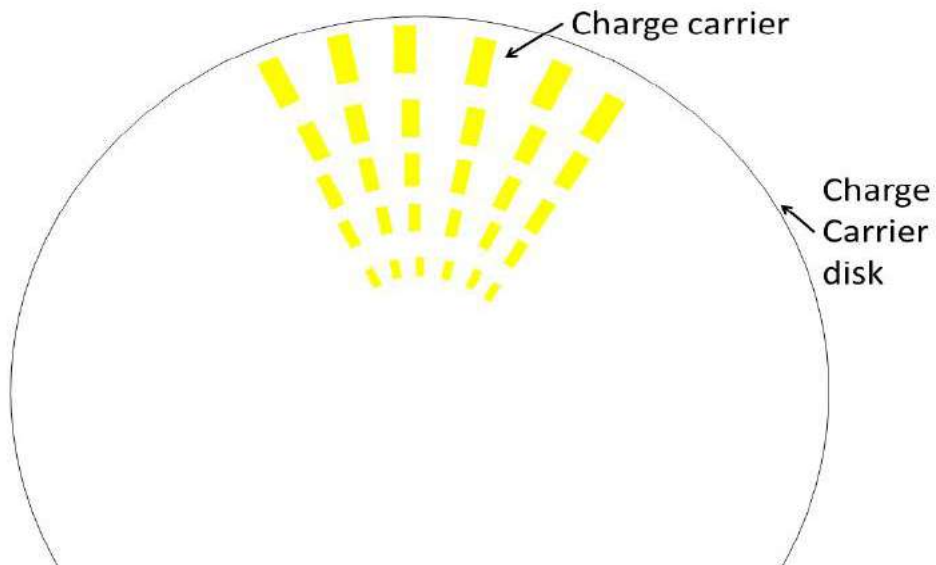

Fig. 15: Plane view of the charge carrier disk in that the charge carriers is reduced to 1/100.

Table 1 shows the simulation condition of the first row on the charge carrier disk.

*Table 1:* Simulation condition of the first row

Parts	Category	First row	Unit
Charge carrier	Thickness	2	$\mu\text{m}$
	Height	104	$\mu\text{m}$
	Width	102	$\mu\text{m}$
	Length	600	$\mu\text{m}$
Injection electret	Thickness	8	$\mu\text{m}$
	Width	160	$\mu\text{m}$
	Length	600	$\mu\text{m}$
	Charge density	0.2	$\text{mC}/\text{m}^2$
Parts	Surface Potential	180	Volts
	Thickness	8	$\mu\text{m}$
	Width	64	$\mu\text{m}$
	Length	600	$\mu\text{m}$
Driving electret	Charge density	1	$\text{mC}/\text{m}^2$
	Surface Potential	900	Volts
	Thickness	8	$\mu\text{m}$
	Width	192	$\mu\text{m}$
Collection electrode	Length	600	$\mu\text{m}$
	Surface Potential	0	Volts
	Thickness	48	$\mu\text{m}$
Disk base plate	Height	180	$\mu\text{m}$
	Width	1206	$\mu\text{m}$
Distances	Injection distance	10	$\mu\text{m}$
	Fe1 distance	330	$\mu\text{m}$
	Fe2 distance	320	$\mu\text{m}$

The injected charge quantity and the electrostatic force that acts on this charged charge carrier was simulated by a two-dimensional finite difference method with table 1 conditions.

The injected charge quantity became  $-1.53\text{e-}11$  [C] and the simulated electrostatic force is shown in Fig. 16.

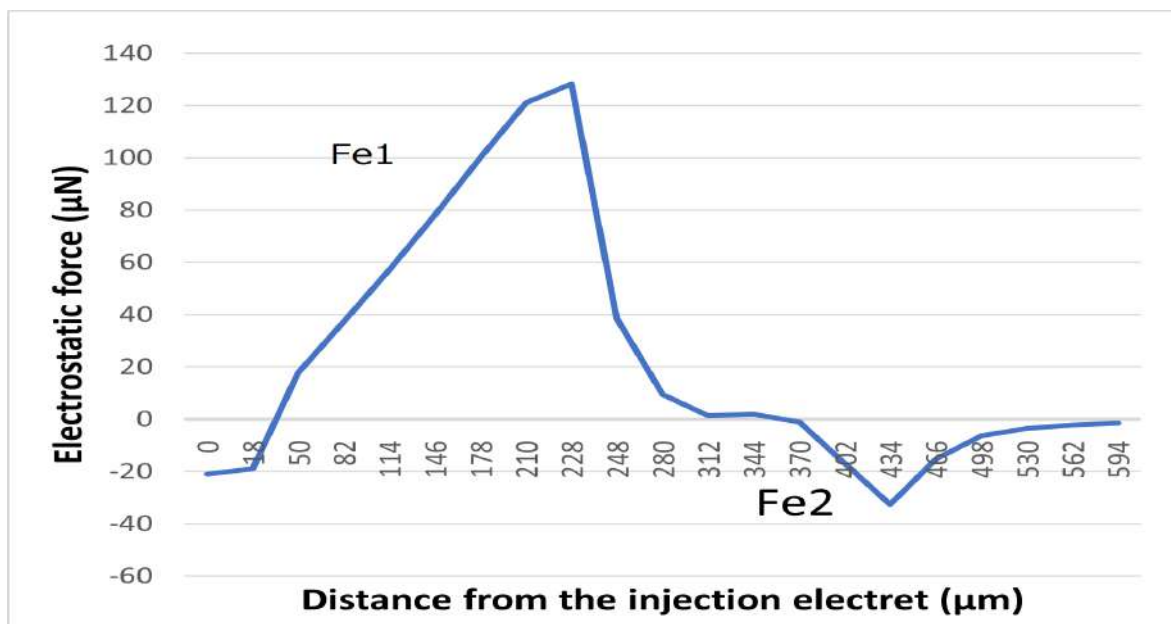

*Fig. 16:* Distance from the injection electret ( $\mu\text{m}$ ) and electrostatic force that acts on the charge carrier on first row

It is apparent from this graph that the forward force  $F_{e1}$  is very strong and the backward force  $F_{e2}$  is very weak. As a result, the large extra energy remains when the charge carrier arrives at the collection electrode. It was  $1.21 \times 10^{-8}$  [J]. The carried charge quantity was  $-1.53 \times 10^{-11}$  [C], therefore, this charge can be lift up to  $-794$  [V] by this extra energy.

One charge carrier transports  $-1.53 \times 10^{-11}$  [C] when it traverse in the one unit. There are 250 unit on the first row. Therefore, when the charge carrier disk rotates one time,  $-3.79 \times 10^{-9}$  [C] is transported to the collection electrode. There are 250 charge carrier on the first row, therefore, when the charge carrier disk rotates one time,  $-9.49 \times 10^{-7}$  [C] is transported to the collection electrode. The rotation speed of the charge carrier is expected 10,000 rpm in the vacuum. Therefore it rotate 167 times in one second. As a result,  $-1.58 \times 10^{-4}$  [C] is transported to the collection electrode in one second. Namely the current is  $-1.58 \times 10^{-4}$  [A]. And the lifted voltage is  $-794$  [V]. Then the electric output of the first row becomes  $1.26 \times 10^{-1}$  [W].

The electrostatic force that acts on the charged charge carrier on the 33 row was simulated.

The electric output of the 33th row was simulated as  $3.40 \times 10^{-2}$  [W], and the electric output of the second row to 32th row were calculated from the electric output of the first row and 33th row. As a result, Current, Voltage and electric output of the 1 set became  $-4.89 \times 10^{-3}$  A, 538V and 2.63W respectively.

The height of the one set is 0.18mm. Therefore 555 sets can be packed into 100mm cubic box.

As a result, Current, Voltage and electric output of this 100mm cubic box generator became  $-2.71$  A, 538V and 1.46kW respectively [14].

This is a remarkable result, however the manufacturing of this machine is very difficult. There are the following five difficult points from the mechanical viewing.

1. The width of the charge carrier change from 100 micro-meter to 50 micro-meter thirty-three times. Therefore, the manufacturing of those charge carriers become very complex.

2. The thickness of the charge carrier is too thin, it is only 2 micro-meter. When the charge carrier pass between the driving electrets, a strong electrostatic force acts on it upper and lower direction. As a result, the shape of the thin charge carrier can't be kept.
3. The rotation speed of the charge carrier disk is too fast, it is 10,000 rpm. The thin charge carrier will be destroyed by centrifugal force.
4. The distance between the injection electret and the side plate of the charge carrier is too narrow. It is only 10 micro-meter. When the charge carrier disk a little vibrates, the both touch each other and the charge carrier will be crashed.
5. The width of the driving electret is too narrow. It is only 64 micro-meter. A narrow width electret is usually produced by a Teflon resin coating. However less than 100 micro-meter width is difficult.

Therefore, the target of this paper is to solve the five problems and present the possible manufacturing method of the field driven generator.

## II. POSSIBLE MANUFACTURING METHOD OF THE FIELD DRIVEN GENERATOR

### 2.1 *The improved shape of the charge carrier and its manufacturing method*

The manufacturing of thirty-three different width of charge carrier is very hard. Therefore, the thirty-three different width charge carriers were packed into one long charge carrier described as in fig.17. And the different width injection electret, driving electret and collection electrode were changed to long injection electret, long driving electret and long collection electrode.

Fig. 18 shows the new charge carrier disk that has long charge carriers and fig.19 shows the new electrode disk that has long injection electrets, long driving electrets and long collection electrodes. The above-mentioned problem 1 is solved with this long charge carrier.

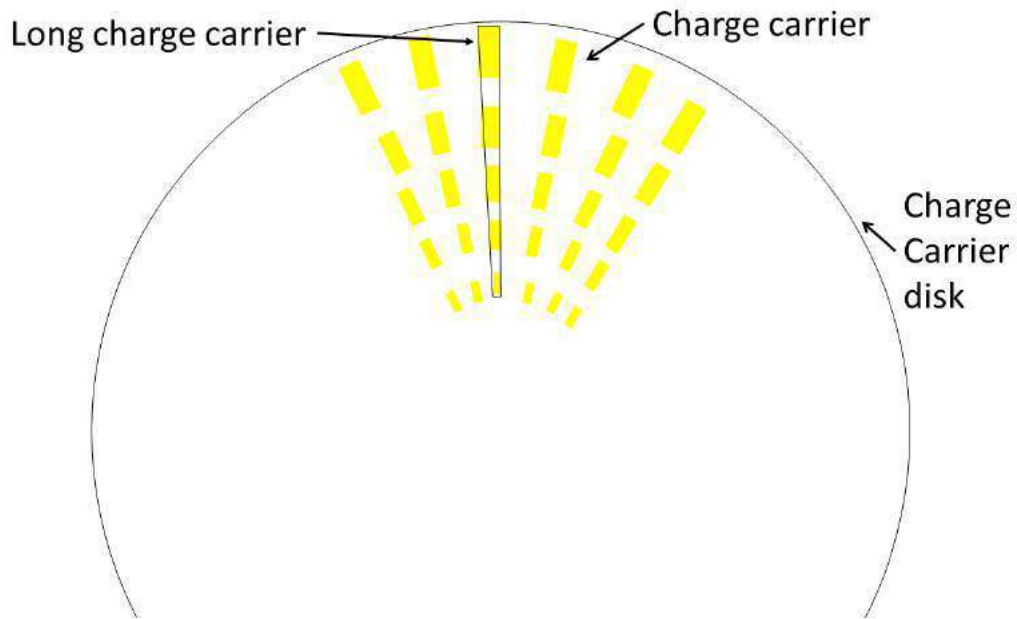

Fig. 17: Plane view of many different width charge carriers and one long charge carrier

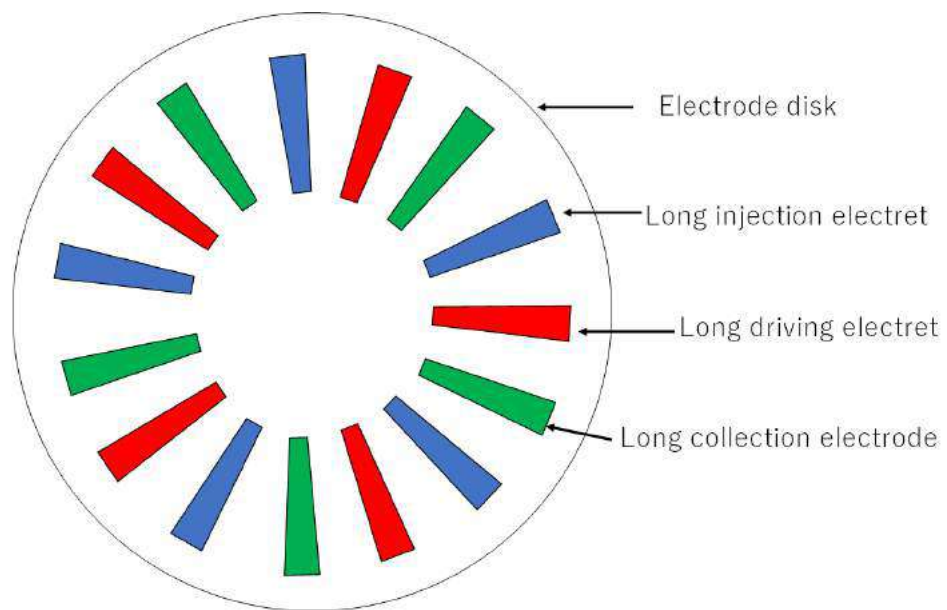
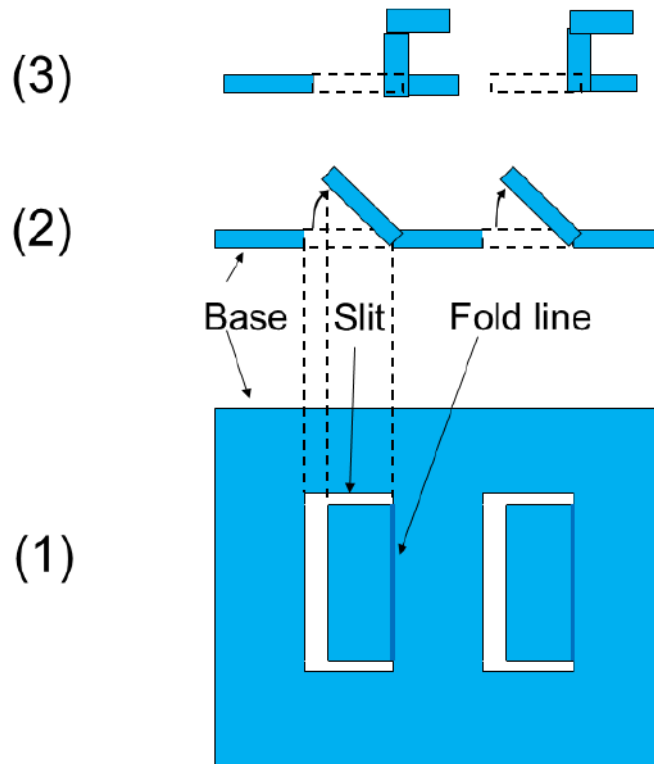

Fig. 18: Plane view of the improved electrode disk that has long injection electret, long driving electret and long collection electrode

The new charge carrier disk that has long charge carriers can be produced from one Aluminum circle plate. Because the shape of the long charge carrier is simple. At first, fig.19 shows the producing method when the width of the long charge carrier is constant.



*Fig. 19:* The producing method when the width of the long charge carrier is constant

At first step, three slits are cut by laser beam on a thin Aluminum base plate and one- fold line is made as shown in fig.19 (1). Next, the three slits area is folded up as shown in fig.19 (2). Finally, this area is two times folded to right angle as shown in fig.19 (3).

As a result, side down gutter shape charge carriers have been made. This is a very simple production method of the charge carrier disk that has many long charge carriers.

Next, the manufacturing method of the charge carrier disk that has width changing long charge carrier is explained more concretely.

The width, the height, the thickness and the length of the long charge carrier was selected as 1.0 to 0.5mm, 1.0mm, 0.02mm and 25.0mm respectively as shown in fig. 20 for easy manufacturing.

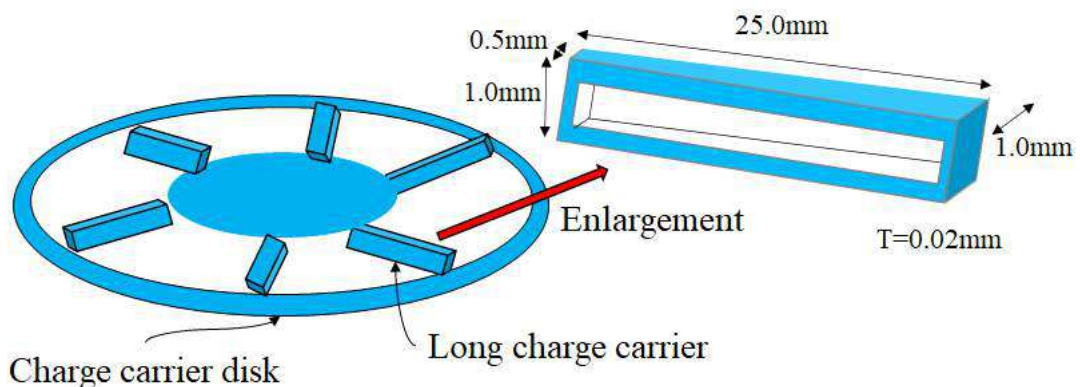

*Fig. 20:* The shape and the measurement of the width changing long charge carrier

Figure 21 shows the manufacture method of this charge carrier disk.

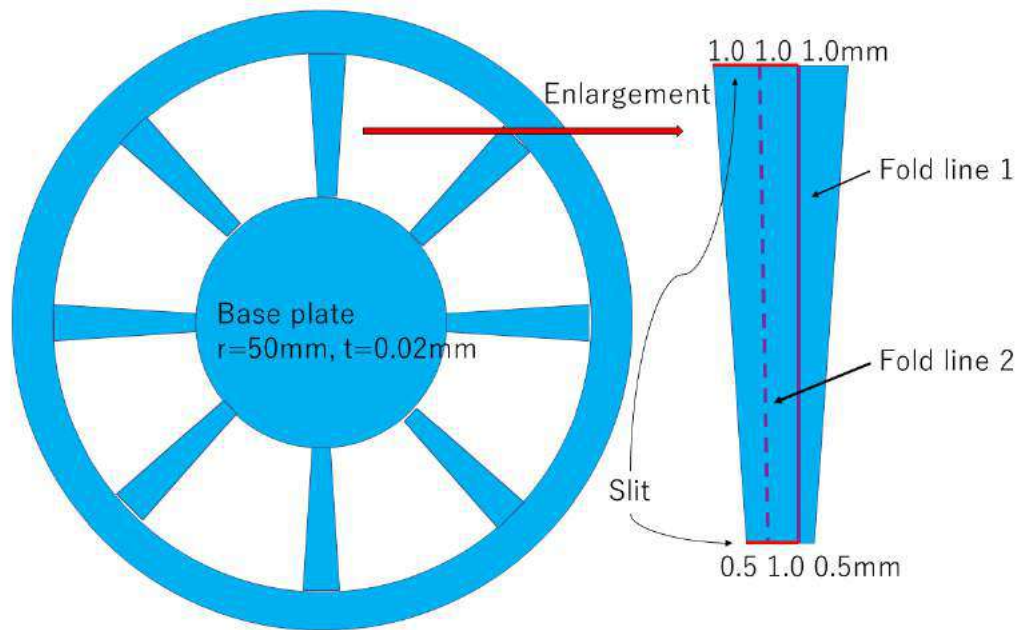

Fig. 21: The explain figure of manufacturing of the width changing long charge carriers

The manufacturing methods consists of the following six steps.

Step 1: Preparing the base plate for the charge carrier disk. Its radius is 50mm and thickness is 0.02mm.

Step 2: The non-used areas are cut out as shown in fig.21. As a result, trapezoidal areas with sides 3, 25, 2.5, 25mm are remained.

Step 3: 3.0mm slit is cut at the upper side of the trapezoid and 2.5mm slit is cut at the lower side of the trapezoid. The slits are shown with red line in fig.21.

Step 4: Fold line 1 and fold line 2 are made on the trapezoid as shown in fig.21.

Step 5: The left area of the trapezoid is folded with fold line 1 perpendicularly to the base plate.

Step 6: The left of the folded area is folded with fold line 2. As a result, this area becomes parallel to the base plate.

This is a mechanically simple method. Therefore, a lot of charge carrier disk will be produced on line automatically.

And finally three charge carrier disks are piled with two thin non-conductive layers. The distance between the carriers on the different disk is kept 3.79 mm.

## 2.2 The electric output of the long charge carrier generator

The thickness of the charge carriers are increased from  $2\mu\text{m}$  to  $20\mu\text{m}$  for possible manufacturing. As a result, the above-mentioned problem 2 will be solved. However, its electric output will decrease. Now, the above-mentioned problem 1 and 2 are solved. However, problem 3, 4, 5 are remain. Therefore, the rotation speed of the charge carrier disk is reduced from 10,000 rpm to 1,000 rpm for solving the problem 3. The distance between the injection electret and the side plate of the charge carrier is expanded from  $10\mu\text{m}$  to  $100\mu\text{m}$  for solving the problem 4. And the width of the driving electret is expanded from  $64\mu\text{m}$  to  $600\mu\text{m}$  for solving the problem 5.

The size of all parts of the generator are enlarged with the above changing as shown in table 2

Those width are the size on the upper side of four trapezoid parts, namely the long charge carrier, the long injection electret, the long driving electret and the collection electrode. Those width reduce to half on the lower side of four trapezoid parts. For example, the width of the long charge carrier on the upper side is 1.0mm, however it reduces to 0.5mm on the lower side.

Simulation with changing the width gradually is impossible with two-dimension finite difference method. Therefore, this width is fixed at 0.76mm on the following simulation.

The results of the both simulation methods are expected about same. Table 3 shows the simulation conditions with 0.76mm charge carrier.

*Table 2:* Simulation condition of short and long charge carriers

Parts	Category	Short carrier	Long carrier	Unit
Charge carrier	Thickness	2	20	$\mu\text{m}$
	Hight	104	1000	$\mu\text{m}$
	Width	102	1000	$\mu\text{m}$
	Length	600	25000	$\mu\text{m}$
Injection electret	Thickness	8	20	$\mu\text{m}$
	Width	160	1500	$\mu\text{m}$
	Length	600	25000	$\mu\text{m}$
	Charge density	0.2	0.1	$\text{mC}/\text{m}^2$
Parts	Surface Potential	180	225	Volts
	Thickness	8	20	$\mu\text{m}$
	Width	64	600	$\mu\text{m}$
	Length	600	25000	$\mu\text{m}$
Driving electret	Charge density	1	1	$\text{mC}/\text{m}^2$
	Surface Potential	900	2250	Volts
	Thickness	8	20	$\mu\text{m}$
	Width	192	2000	$\mu\text{m}$
Collection electrode	Length	600	25000	$\mu\text{m}$
	Surface Potential	0	0	Volts
	Thickness	48	500	$\mu\text{m}$
Disk base plate	Hight	180	1740	$\mu\text{m}$
	Width	1206	11360	$\mu\text{m}$
	Length	600	25000	$\mu\text{m}$
Distances	Injection distance	10	100	$\mu\text{m}$
	Fe1 distance	330	3200	$\mu\text{m}$
	Fe2 distance	320	3200	$\mu\text{m}$

*Table 3:* Simulation condition of 0.76mm charge carriers

Parts	Category	Short carrier	Long carrier	0.76mm carrier	Unit
Charge carrier	Thickness	2	20	20	$\mu\text{m}$
	Hight	104	1000	1000	$\mu\text{m}$
	Width	102	1000	760	$\mu\text{m}$
	Length	600	25000	25000	$\mu\text{m}$
Injection electret	Thickness	8	20	20	$\mu\text{m}$
	Width	160	1500	1120	$\mu\text{m}$
	Length	600	25000	25000	$\mu\text{m}$
	Charge density	0.2	0.1	0.1	$\text{mC}/\text{m}^2$
Parts	Surface Potential	180	225	225	Volts
	Thickness	8	20	20	$\mu\text{m}$
	Width	64	600	480	$\mu\text{m}$
	Length	600	25000	25000	$\mu\text{m}$
Driving electret	Charge density	1	1	1	$\text{mC}/\text{m}^2$
	Surface Potential	900	2250	2250	Volts
	Thickness	8	20	20	$\mu\text{m}$
	Width	192	2000	1600	$\mu\text{m}$
Collection electrode	Length	600	25000	25000	$\mu\text{m}$
	Surface Potential	0	0	0	Volts
	Thickness	48	500	500	$\mu\text{m}$
Distances	Injection distance	10	100	100	$\mu\text{m}$
	Fe1 distance	330	3200	2400	$\mu\text{m}$
	Fe2 distance	320	3200	2400	$\mu\text{m}$
One unit	Hight	180	1740	1740	$\mu\text{m}$
	Width	1206	11360	8650	$\mu\text{m}$
Base plate	Thickness	48	500	500	$\mu\text{m}$

The injected charge quantity to the charge carrier when it passes between the injection electret was simulated as  $-1.002$  [nC]. Then the electrostatic force that acts on the charged charge carrier was simulated while the charge carrier leaves the injection electret and reaches to the collection electrode. Fig.22 shows the simulation result.

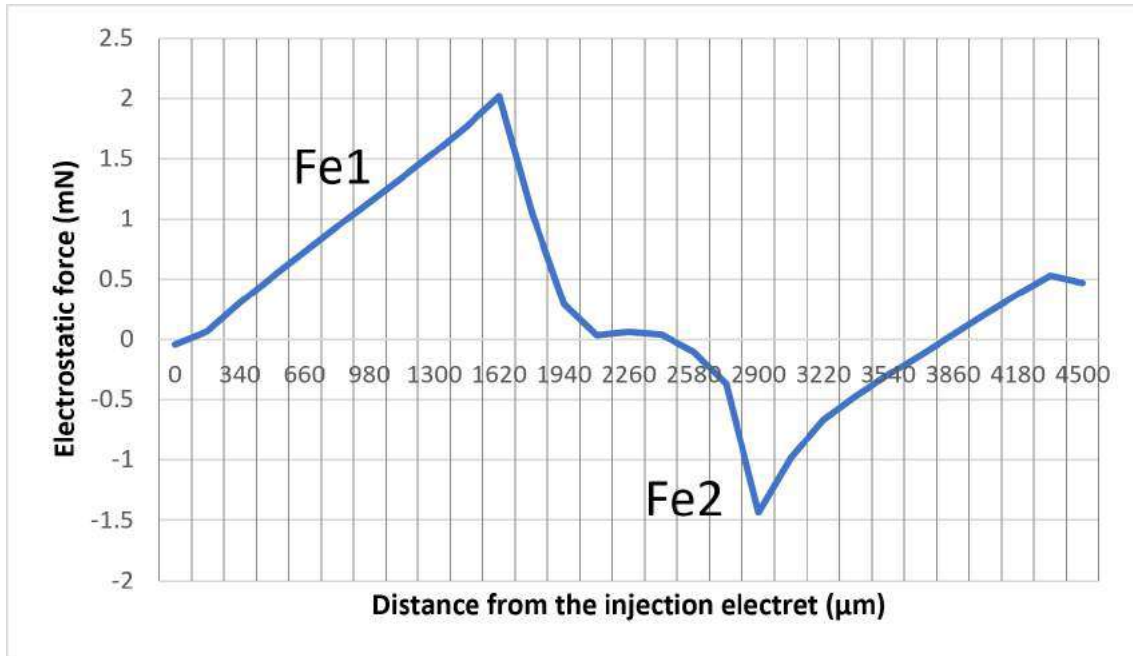

Fig. 22: The electrostatic force that acts on the charge carrier with thickness 20 micro-meter

In fig.22 the backward electrostatic force fe2 became positive when the charge carrier close to the collection electrode. This phenomenon happens depend on a strong image force. This unique phenomenon will be discussed on the next paper.

The extra energy was calculated as  $1.445$  [ $\mu$ J] from the electrostatic force shown in fig.22. As a result, the transported charge  $-1.00$  [nC] was lifted up to  $-1445$  [V] by this extra energy.

There are 81 charge carriers on the charge carrier disk and there are 27 units on the electrode disk, and the charge carrier disk rotate 16.7 times per second. As a result, the current of this generator became  $-3.65e-5$  [A]. Namely, its electric output is  $5.27e-2$  [W] for one set.

The height of the one set is 1.74mm. Therefore, 57 sets were piled in 100 mm cubic box. Therefore, the electric output from 100 mm cubic generator became 3.00 [W]. And it became 3.00 [kW] for 1.0 m cubic generator. This generator will be useful for the non-electric area.

This generator will be useful even if its electric output became half.

Therefore, 40 and 60 micro-meter thickness charge carrier's electric output was simulated because 20 micro-meter Aluminum plate may be weak mechanically. The simulation condition of those two generators were the same without its charge carrier thickness as the simulation condition of the 20 micro-meter generator shown in Table.3.

The injected charge quantity of 40 micro-meter charge carrier became  $-1.007$  [nC] and The injected charge quantity of 60 micro-meter charge carrier became  $-1.014$  [nC] The simulated electrostatic force that acts on those charged charge carrier was shown in fig.23.

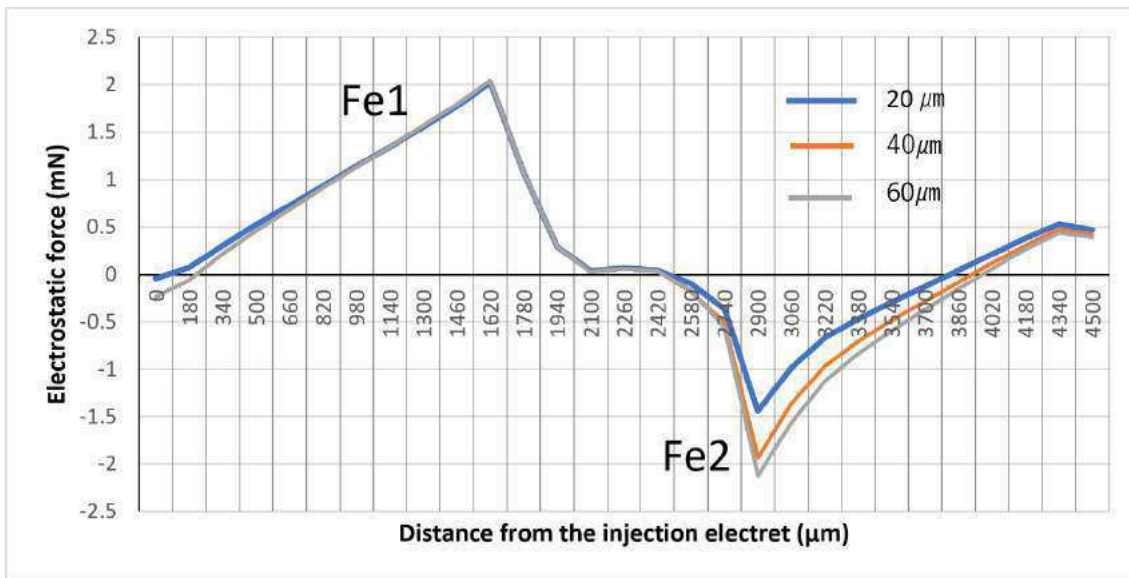

Fig. 23: The electrostatic force that acts on the charge carrier with thickness 20, 40, 60 micro-meter

The forward electrostatic force Fe1 that acts on the charge carrier with thickness 60 micro-meter was not simulated because the force is same as the force that acts on the charge carrier with thickness 40 micro-meter.

The voltage of the unit that has the 40 micro-meter charge carrier became -981 [V] and the voltage of the unit that has 60 micro-meter charge carrier became -797 [V].

As a result, the electric output of the 100 mm cubic generator that has the 40 micro-meter charge carrier became 2.04 [W] and the electric output of the 100 mm cubic generator that has the 60 micro-meter charge carrier became 1.67 [W].

Namely, the electric output of 1.0 m cubic generator that has 40 micro-meter charge carrier became 2.04 [kW] and the electric output of 1.0 m cubic generator that has 60 micro-meter charge carrier became 1.67 [kW]. a 40 or 60 micro-meter Aluminum plate may be stable mechanically.

However, more thickness may be required. Therefore, the electric output of the 1.0 m cubic generator that has 80 and 100 micro-meter charge carrier were estimated from the data of 20, 40,60 micro - meter charge carrier generator. Fig.24 shows the estimated electric output.

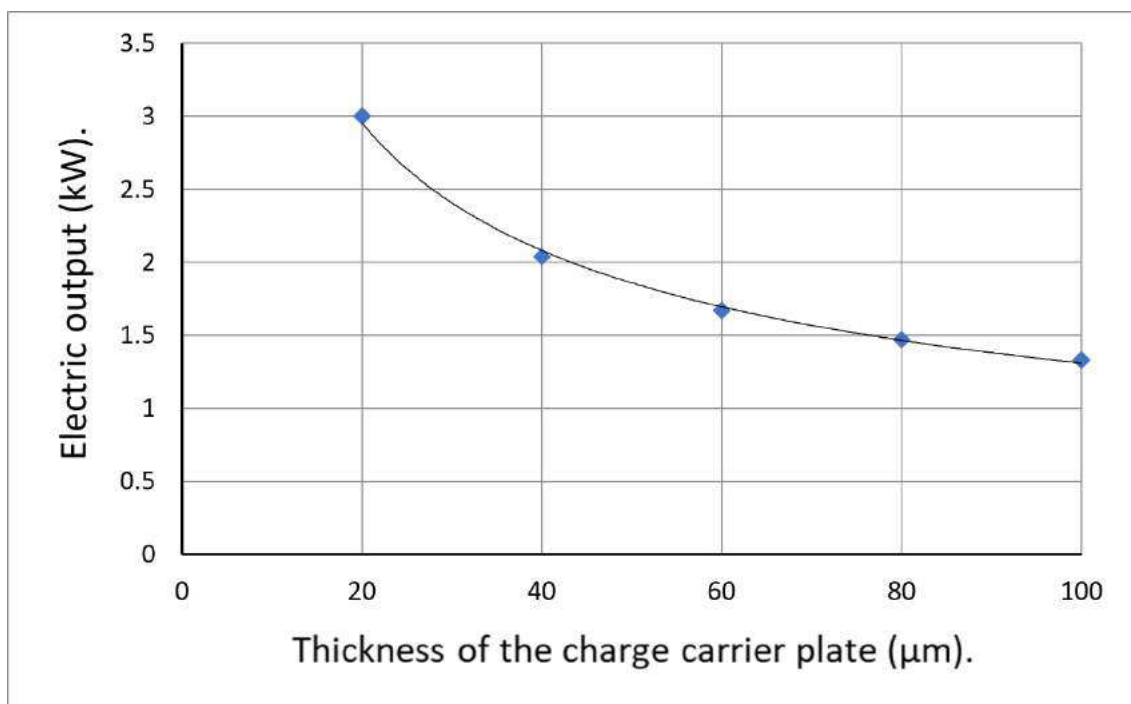

Fig. 24: The estimated electric output for 1.0 m cubic generator that has 80 and 100  $\mu\text{m}$  thickness charge carrier

The estimated electric output of 1.0 m cubic generator that has 80 or 100  $\mu\text{m}$  thickness charge carrier became 1.47 [kW] and 1.33 [kW] respectively. Namely the electric output of the 100  $\mu\text{m}$  thickness generator is less than half to that of the 20  $\mu\text{m}$  thickness generator. However if the rotation of the 100  $\mu\text{m}$  thickness generator is more stable than the rotation of the 20  $\mu\text{m}$  thickness generator, the rotation speed can be increased to 2000rpm or 3000rpm from 1000rpm, as a result its electric output becomes two or three times. And the injection distance can be reduced to 50 $\mu\text{m}$  from 100 $\mu\text{m}$ , as a result, the injected charge quantity becomes two times. Namely the electric output of the 100 $\mu\text{m}$  thickness generator becomes more than two times of the 20  $\mu\text{m}$  thickness generator.

### III. CONSIDERATION

The electric output of the field driven generator that consists of 100  $\mu\text{m}$  thickness charge carrier is not large. However, it will be enough for erasing the non-electric area from the earth.

Of course, many problems must be solved for manufacturing it. One of them is a rotation mechanism of the charge carrier disk. We must

select a suitable ball bearings. One of the suitable ball bearings is ADB (autonomous decentralized bearing) bearings invented by Mr. Kawashima [15]. Because the frictional main reason of a conventional bearings is the increase in slide friction between the balls and the retainer of the ball. ADB bearings make it so the loaded balls are not in contact with each other without using a retainer.

However, a magnetic levitation rotation may be used in the near future in place of a ball bearings.

The other problem is a narrow width electret. Many electret maker in Japan stopped to product an electret recently. However the following company continues to produce an electret and has an experience to made 100 $\mu\text{m}$  width electret.

TOHO KASEI CO. ,LTD <https://www.toho-kasei.co.jp/>

### IV. CONCLUSION

It can be expected that the commercial manufacturing of the field driven generator will become possible with the long charge carrier, its new manufacturing methods and the suitable parts size. The electric output of this field driven

generator is now expected 1 ~3 [kW] for 1.0 meter cubic machine. However, the electric output will increase year by year with improving mechanical precision.

## REFERENCES

1. David Halliday, Robert Resnick, Jearl Walker, Fundamentals of Physics. 6th edition Japanese version Chapter "Electric Charge" question 1, Wiley & sons. Inc.
2. K. Sakai, et al., Electrostatics: Theory and Applications, first ed. Nova Science Publish, New York, 2010 (Chapter 1).
3. K. Sakai, Asymmetric Electrostatic Forces and a New Electrostatic Generator, first ed. Nova Science Publish, New York, 2010.
4. K. Sakai, "The electrostatic force that acts on the charged asymmetric conductor in a high electric field," Proceedings of 2009 Electrostatics Joint Conference (2009) P2.07.
5. K. Sakai, "Electrostatic force that acts on non-sphere shape charged conductors", Proceedings of 2010 ESA annual Conference (2010) G4.
6. K. Sakai, "A simple experiment result that confirmed asymmetric electrostatic force", Proceedings of 2011 ESA annual Conference (2011) B4.
7. K. Sakai, "Asymmetric electrostatic force", Journal of Electromagnetic Analysis and Applications 2014 on the Special Issue on Electromagnetic Field Theory, pp.253-pp.268.
8. K. Sakai, "Theory of Asymmetric electrostatic force", Journal of Electromagnetic Analysis and Applications Vol.09 No.02 (2017).
9. K. Sakai, "The third trial for the new electrostatic generator that is driven by Asymmetric electrostatic force", Proceedings of 2017 ESA annual Conference (2017) A3.
10. K. Sakai, "The Electric Field Driven Generator", Global Journal of Computer Science Technology :C Vol.19 Issue 2 (2019) pp.1-pp.15
11. K. Sakai, "A New Charge Injection Method of the Electric Field Driven Generator", Proceedings of 2019 ESA annual Conference (2019) A4.
12. K. Sakai, "A new electrostatic Generator Driven by only an Electric Field of an Electret" Journal of Electromagnetic Analysis and Applications Vol.13 No. 12 (2021) pp.161-pp.171.
13. K. Sakai, "Study about a New Electrostatic Generator Driven by Only an Electric Field of an Electret" New Trends in Physical Science Research Vol.2, by Book Publisher International.
14. K. Sakai, "The increasing method of the electric output of the field driven generator", London Journal of Engineering Research Volume 22, Issue 2.
15. Home page of Coo Space Co.,LTD. <http://www.coo-space.com>.

*Note, the field driven generator has the following features.*

1. No maintenance or energy supply required (in the case of magnetic levitation rotation, lubrication is required for bearings).
2. Does not generate CO<sub>2</sub>.
3. Miniaturization is possible.
4. The parts required for manufacturing are common and the product cost is low.
5. Long life (the life of the electret is 100 years).
6. The output is stable.
7. No danger (during manufacturing, use, disposal)
8. Lightweight.
9. Directly connected power supply for each electric product, eliminating the need for power transmission lines and capacitors.

*As its application, for example*

- Elimination of non-electric areas, temporary power supply in disaster areas, power supply in nuclear shelters.
- Use in space where sunlight does not reach (beyond Jupiter).
- Use inside the body where energy cannot be supplied from the outside, such as an artificial heart.
- Electronic devices that need to be charged frequently, such as smartphones and PCs.
- Power supply for radiotelephone relay stations. It can be installed on telephone poles without the need for solar cells or storage batteries.
- Power supply for equipment (traffic signals, emergency guidance) required even during a power outage.

- Power supply for meteorological observation equipment that is difficult to replace batteries in the sea, in tunnels, on mountain peaks, etc. And so on.

*This page is intentionally left blank*



Scan to know paper details and  
author's profile

# Simulation Analysis and Research on the Influence of Three-Wave Point Trajectory in the Explosion Field

*Yi-Kang Tang & Chun-Dong Xu*

*Nanjing University of Science and Technology*

## ABSTRACT

Predicting the location of the three-wave point and the changing law of the three-wave point is of great significance for accurately assessing the power of large-yield explosives or warheads. Based on the AUTODYN finite element analysis software, the three-wave point trajectory in the explosion field is studied by numerical simulation. The preliminary analysis shows that in the blast field, the explosion shock wave always spreads around the explosive center, and the three-wave point height trajectory Both maintain a rising trend. In the midfield (burst distance 4.0~7.0m), regardless of changing the charge equivalent, explosion height, initiation point position, size, material and reflection interface, the three-wave point height increase rate is relatively slow, while in the far field (burst center distance >7.0m) The growth rate is relatively fast. When the explosive height of the explosive does not change, change the explosive equivalent. The smaller the equivalent, the higher the three wave points at the same measuring point. When the explosive equivalent is unchanged, change the explosion height, the smaller the explosion height, the higher the three wave points at the same measuring point. The change of the initiating point position in the midfield has little effect on the three-wave point trajectory. The higher the initiating point position in the far field, the faster the three-wave point trajectory increases.

*Keywords:* three wave points; numerical simulation; equivalent; explosion point location; explosion height.

*Classification:* DDC Code: 303.4840973 LCC Code: HN57

*Language:* English



LJP Copyright ID: 392954

Print ISSN: 2631-8474

Online ISSN: 2631-8482

London Journal of Engineering Research

Volume 22 | Issue 4 | Compilation 1.0



# Simulation Analysis and Research on the Influence of Three-Wave Point Trajectory in the Explosion Field

Yi-Kang Tang<sup>a</sup> & Chun-Dong Xu<sup>σ</sup>

## ABSTRACT

*Predicting the location of the three-wave point and the changing law of the three-wave point is of great significance for accurately assessing the power of large-yield explosives or warheads. Based on the AUTODYN finite element analysis software, the three-wave point trajectory in the explosion field is studied by numerical simulation. The preliminary analysis shows that in the blast field, the explosion shock wave always spreads around the explosive center, and the three-wave point height trajectory Both maintain a rising trend. In the midfield (burst distance 4.0~7.0m), regardless of changing the charge equivalent, explosion height, initiation point position, size, material and reflection interface, the three-wave point height increase rate is relatively slow, while in the far field (burst center distance >7.0m) The growth rate is relatively fast. When the explosive height of the explosive does not change, change the explosive equivalent. The smaller the equivalent, the higher the three wave points at the same measuring point. When the explosive equivalent is unchanged, change the explosion height, the smaller the explosion height, the higher the three wave points at the same measuring point. The change of the initiating point position in the midfield has little effect on the three-wave point trajectory. The higher the initiating point position in the far field, the faster the three-wave point trajectory increases.*

**Keywords:** three wave points; numerical simulation; equivalent; explosion point location; explosion height.

**Author a σ:** School of Mechanical Engineering, Nanjing University of Science and Technology, Nanjing City, Jiangsu Province, China, 210094.

## I. INTRODUCTION

When the ammunition in the air explodes, the nearby medium will be squeezed by the huge energy of the ammunition, which causes the energy in the air to increase sharply, thus forming an explosive shock wave [1]. In order to accurately assess the power of large explosives or warheads, it is necessary to measure the shock wave pressure of the ammunition. The shock wave pressure is divided into free field pressure and ground reflected pressure. The measured ground launch pressure is greatly affected by the surface environment so that the measured The value does not meet the requirements, so in order to better evaluate the power of the explosive, it is obviously more appropriate to choose the free field pressure of the ammunition. Only a reasonable choice of the location of the free field pressure sensor can measure the free field of the ammunition more accurately. Therefore, studying the changes of the three-wave point trajectory has guiding significance for the layout of the free-field pressure sensor.

Scholars at home and abroad have carried out many related studies on the three wave points of the explosion field. Guo Wei [2] used the method of adjusting the height of the PCB137 free-field pressure sensor at the same measuring point, and obtained the changing law of the three-point trajectory of the explosion shock wave through multiple experiments. Qiao Dengjiang [3] extensively analyzed the results of free-field explosion tests, and finally summed up the empirical formula for the height of the three wave points of the explosion shock wave of TNT explosives. Du Hongmian [4] studied the propagation law of shock waves by comparing the results of explosive explosion experiments with theoretical values. Duan Xiaoyu and others

studied the numerical simulation of the three-wave point height of RDX-based aluminum-containing explosives, and obtained the three-wave point characteristics of three different explosives in the air [5]. Qu Yandong et al. concluded that the shape of the explosive has a greater influence on the height of the three wave points [6]. Wang Feng [7] used LS-DYNA numerical simulation to study the formation process and trajectory of the three wave points of the penetration bomb explosion field. Zhang Xuelun [8] used AUTODYN explicit finite element program to simulate the explosion field, and compared the simulation results with the experimental data. At present, there are relatively few problems in studying the influence of a single variable of explosives on the trajectory of the three-point trajectory of the explosion shock wave.

## II. THE GENERATION OF THREE WAVES

Based on the basic theory of explosive shock wave, the AUTODYN explicit finite element program is used to numerically simulate the process of explosive air explosion, forming a three-wave point trajectory on the reflective interface, and explore the influence of a single variable of the explosive on the three-wave point trajectory.

The actual ammunition charge is mostly cylindrical, and its explosive products will diffuse to the surrounding at a very fast speed to form a

spherical shock wave. As the shock wave propagates outwards, the rigid surface is squeezed by the shock wave and there is a reflection phenomenon, which is the reflected wave. The reflections generated on rigid surfaces can be divided into two types: normal incidence and oblique incidence. When the angle between the normal of the wavefront of the incident wave and the normal of the reflecting surface (called the "incident angle"), When it is zero, the reflection process of the shock wave on the rigid surface at this time is called regular reflection; When it is not zero, it is called oblique incidence. At this time, there are two situations. When the incident angle exceeds a certain limit angle, the incident wave and the reflected wave form a new shock wave on the reflecting surface, which is Mach wave [9], This kind of reflection is called Mach reflection or irregular reflection. When the incident angle is less than a certain limit angle, the oblique reflection is called normal reflection.

The intersection of the incident wave, the reflected wave and the Mach wave is the three wave point. When the time and the burst center distance change, the position of the three wave point will also change. Figure 1 is a schematic diagram of the air pressure field distribution when the charge explodes near the ground. It can be seen from Figure 1 that the trajectory of the three wave points is a concave upward curve.

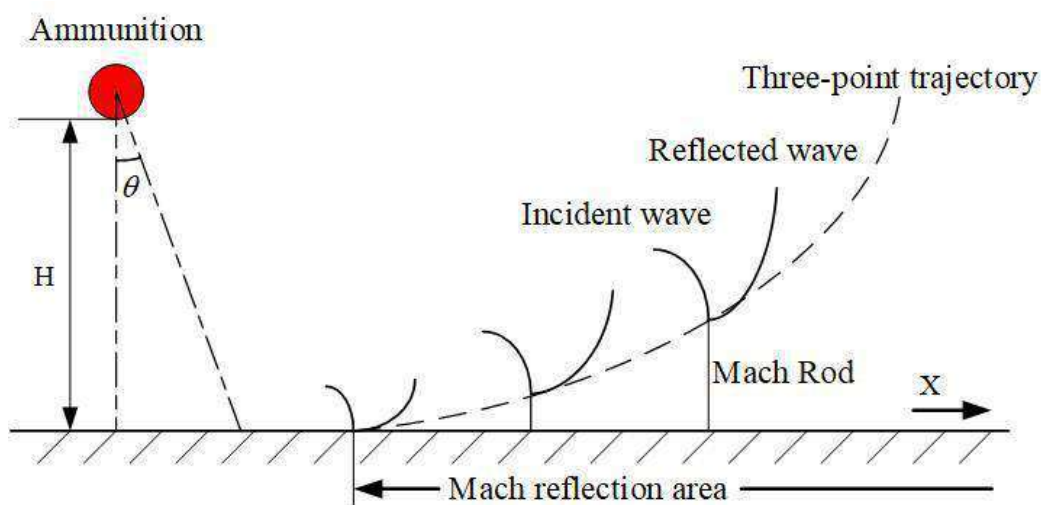

Figure 1: Schematic diagram of near-ground explosion field

### III. Numerical Simulation

#### 3.1 Establishment of finite element model

The finite element model in the simulation test needs to be established according to the physical

model in the test, so as to provide a reference for the research of the test method and the layout of the measuring points. The physical model in the test is shown in Figure 2 below:

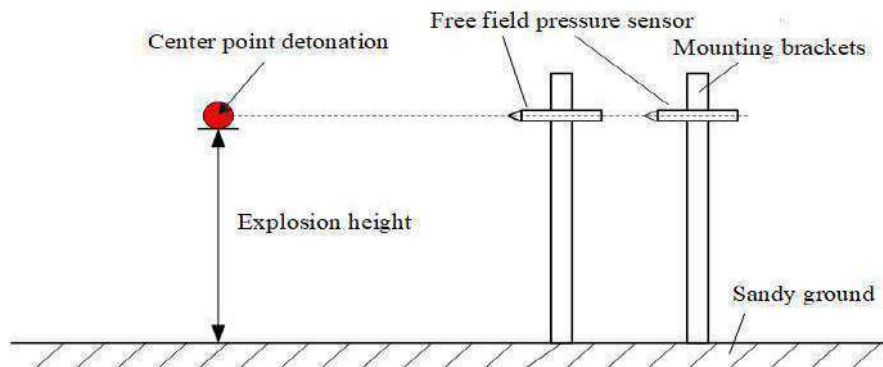

(a) The overall picture of the test physical model

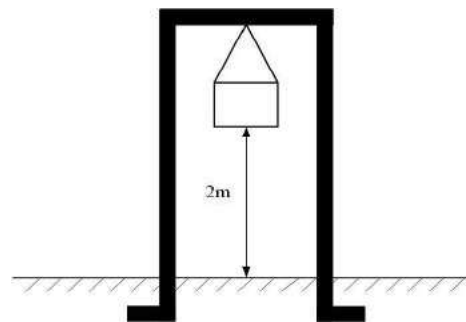

(b) Physical model of grain suspension

Figure 2: Test physical model

The explosion of TNT cylindrical explosive in free field is selected as the calculation model for numerical simulation. The model is divided into three parts: air domain, ground and TNT grains. The size of the air domain is 6000mm×30000mm, the grid of the air domain is 400×1100, the size of the ground is 200mm×30000mm, and the grid of the ground is 20 ×1100, the overall size of the model is 6200mm×30000mm, and the overall grid is divided into 420×1100, all using BOX structure. The calculation model is shown in Figure 3. The TNT grain is placed in the air domain in a filled form. The upper surface and the front surface of the model are set as the outflow boundary to allow the air medium to flow out. The ground material is sand, and the numerical simulation adopts the mm-mg-ms unit system.

When the shock wave pressure is actually measured, the pressure sensor is placed at

different heights and burst center distances to obtain different pressure time history curves, so as to better study the free field shock wave pressure. Modeling can achieve the same purpose as the free field pressure sensor in the actual measurement by setting the Gauss point. A total of 15 Gauss points are set in the model, among which the burst center distances of Gauss points 1, 2, and 3 are 5m, and the heights are 1m, 2m, and 3m respectively; the burst center distances of Gauss points 4, 5, and 6 are 7m, and the heights are respectively 1m, 2m, 3m; the burst center distance of Gauss points 7, 8, and 9 are 9m, and the heights are 2m, 3m, 4m respectively; the burst center distance of Gauss points 10, 11, and 12 are 11m, and the heights are 2m, 3m, 4m, respectively; The burst distances of Gauss points 13, 14, and 15 are 11m, and the heights are 3m, 4m, and 5m respectively.

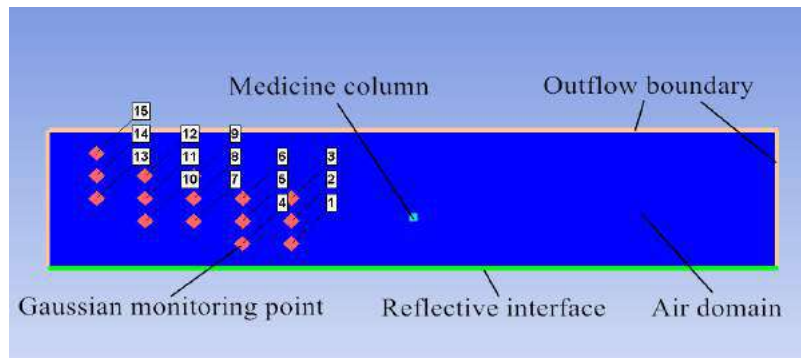

Figure 3: Finite element model

In order to study the influence of the three-wave point trajectory on the charge equivalent, the TNT grain equivalent is 8kg, 20kg, and 50kg respectively through the controlled variable method, the length-to-diameter ratio of the grain is 1:1, the explosion height is 2m, and the initiation point is the charge. The center point of the column detonated.

In order to study the influence of the three-wave point trajectory by the size of the charge, the charge size is 2:1, 1:1, 1:2 by the control variable method, and the TNT charge equivalent is 50kg, the explosion height is 2m, and the detonation point position is the detonation at the center of the grain.

In order to study the influence of the trajectory of the three wave points on the explosion height, the explosion height is 1m, 2m, 3m respectively through the control variable method, the TNT equivalent is 50kg, the TNT length-to-diameter ratio is 1:1, and the detonation point is the center point of the charge.

In order to study the influence of the three-wave point trajectory on the position of the initiation

point of the grain, the initiation point was detonated at the center of the top of the grain, the center of the grain, and the center of the bottom of the grain by the control variable method. The TNT equivalent was selected as 50kg. The length to diameter ratio is 1:1, and the explosion height is 2m.

In order to study the influence of the three-wave point trajectory on the reflective interface material, the reflective interface material was set to sand, steel, and concrete by the control variable method, and the TNT equivalent was 50kg, the TNT aspect ratio was 1:1, and the explosion height was 2m.

In order to study the influence of the three-wave point trajectory on the explosive material, the explosive material was set to TNT and HMX by the control variable method, and the TNT equivalent was 50kg, the aspect ratio was 1:1, and the explosion height was 2m.

As shown in Figure 4, the initiation points of the grains are set at different positions.

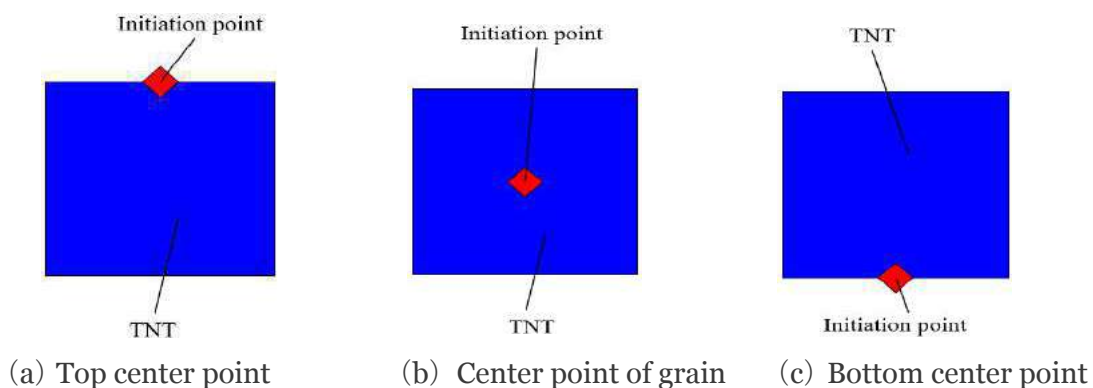

Figure 4: Schematic diagram of different positions of the initiation point of the grain

### 3.2 Material model and equation of state

The explosion process of TNT grains is simulated and analyzed by the JWL equation of state. The expression of the JWL equation of state is:

$$p = A \left( 1 - \frac{\omega}{R_1 V} \right) e^{-R_1 V} + B \left( 1 - \frac{\omega}{R_2 V} \right) e^{-R_2 V} + \omega \rho e \quad (1)$$

It can be seen that the formula is composed of 3 parts. The first term affects the high-pressure part, the second term affects the medium-voltage part, and the third term affects the low-pressure part. Where  $P$  is the gas pressure of the detonation product,  $A$ ,  $B$ ,  $R_1$ ,  $R_2$ ,  $\omega$  are material constants, Get through test fitting,  $\rho$  is the density,  $e$  is internal energy, and  $\eta$  is efficiency.

The material parameters of TNT are listed in Table 1, where the explosive density is the explosive density, and  $D$  is the explosive detonation velocity. The input parameters of TNT materials [10] are shown in Table 1, where  $V_0$  is the initial relative volume,  $D$  is the explosion velocity,  $P_{cj}$  is the explosion pressure, and  $\rho$  is the density.

Table 1: Material parameters of TNT explosives

$\rho/$ (g·cm <sup>-3</sup> )	A/ GPa	B/ GPa	R <sub>1</sub>	R <sub>2</sub>	$\omega$	E <sub>0</sub> / (MJ·m <sup>-3</sup> )	V <sub>0</sub>	D/ (m·s <sup>-1</sup> )	P <sub>cj</sub> / GPa
1.58	373.7	3.74	4.15	0.9	0.35	6000	1.00	6930	21

The constitutive relationship of air materials is described by the Ideal Gas equation of state, which is expressed as follows:

$$p = (\gamma - 1) \rho e + \quad (2)$$

Among them:  $P_{shift}$  is the initial pressure, taken as 100kPa;  $e$  is the internal energy;  $\gamma$  is the ideal gas

constant, taken as 1.4;  $\rho$  is the density, taken as 0.001293g/cm<sup>3</sup>.

The material of the ground model is SAND, and its material parameters are shown in Table 2.

Table 2: Sand and soil material parameters

$\rho/$ (kg/m <sup>3</sup> )	A	N	Q <sub>0</sub>	B <sub>Q</sub>	f <sub>c</sub> / GPa	f <sub>t</sub> / f <sub>c</sub>	f <sub>s</sub> / f <sub>c</sub>
2284	1.62	0.71	0.6645	0.0102	37	0.12	0.19

### 3.3 Calculation results

The model established by the operation of AUTODYN finite element software can observe the pressure cloud diagram of TNT explosion at different times. Figure 5 shows the pressure cloud diagram when the TNT equivalent is 50kg and the charge clearance is 2m.

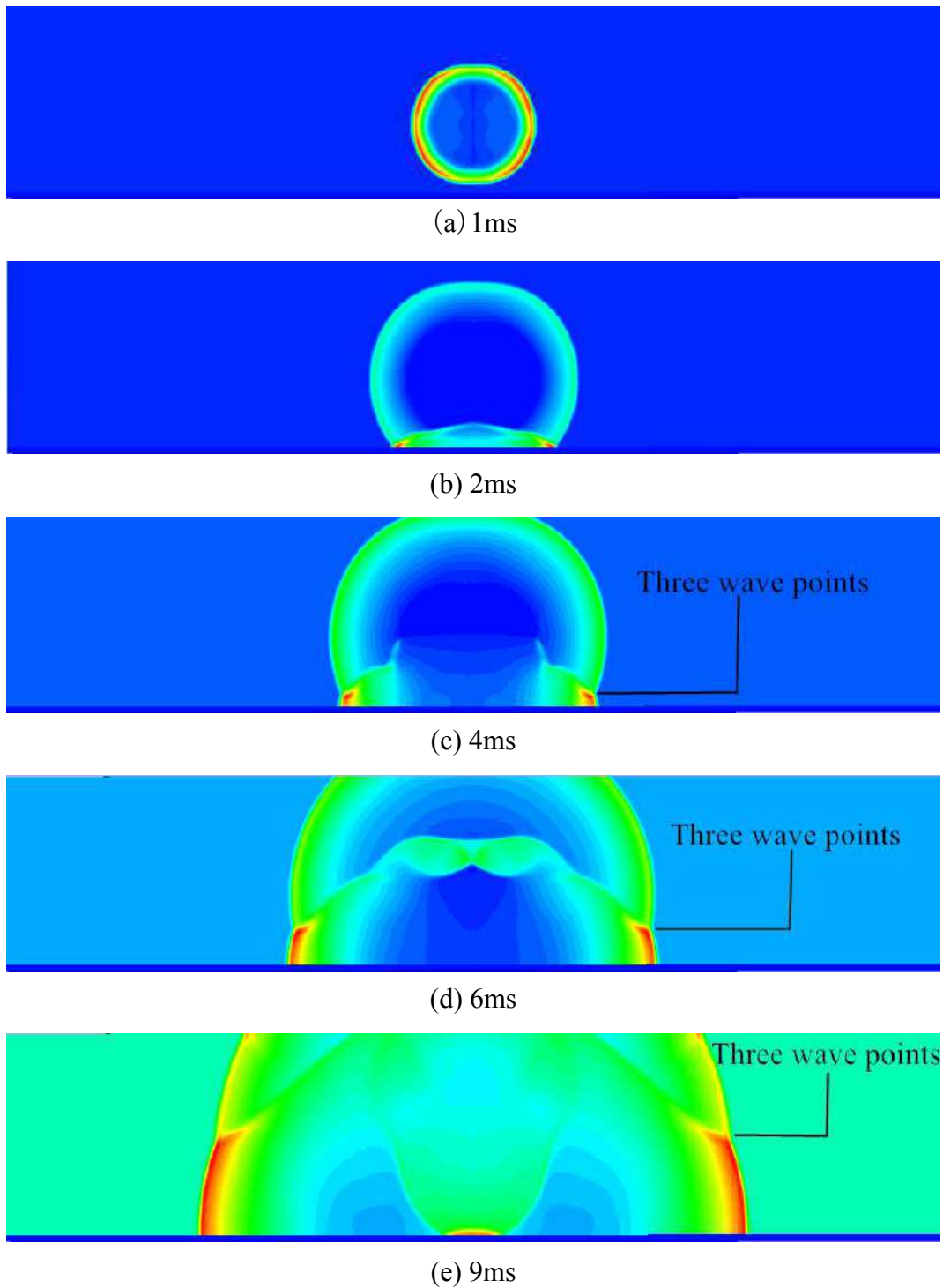

Figure 5: Shock wave pressure cloud diagram at different times

It can be clearly seen from the cloud chart that the three-wave point changes. The three-wave point trajectory presents a concave upward trend, and as time becomes longer, the height of the three-wave point becomes higher and higher.

In order to verify the rationality of the finite element model in Section 3.1, the explosion height

of the TNT grain is 2m, the equivalent size is 2kg, the detonation point is the center point of the grain, and the overall size (length-to-diameter ratio) is 1:2. Model and simulate, and then compare the measured results [11] with the simulation results to prove whether the model in Section 3.1 is reliable. As listed in Table 3.

*Table 3:* Comparison of measured results and simulation results

Horizontal distance /m	4	5	6	7	8	9
Measured value /m	0.31	0.42	0.76	1.01	1.44	1.72
Simulation value /m	0.29	0.45	0.73	1.07	1.46	1.77
error	6.4%	6.7%	3.9%	5.6%	1.3%	2.8%

It can be seen from Table 3 that whether the three wave points are in the midfield (horizontal distance is 4.0~7.0 m) or in the far field (horizontal distance is greater than 7.0 m), the error between the measured results and the simulation results is very small, not more than 10%. The error between the simulation results and the test results is within the allowable range, so the use of AUTODYN software to establish a simulation model can get results consistent with the test results.

grain is 1:1, the explosion height is 2m, and the detonation point is the center point of the grain for simulation calculation. Different burst centers can be obtained from the pressure cloud chart. The height of the three wave points at the distance, as shown in Table 4, is the simulation calculation result.

#### IV. SIMULATION RESULT ANALYSIS

##### 4.1 The three-wave point trajectory is affected by the charge equivalent

The equivalent of TNT grain is 8kg, 20kg, 50kg, the length-diameter ratio of the irrelevant variable

*Table 4:* The height of the three wave points of different charge equivalents at each burst distance

8kg		20kg		50kg	
High/m	Horizontal distance/m	High /m	Horizontal distance/m	High /m	Horizontal distance/m
0.351	3.12	0.342	3.21	0.323	3.15
0.363	3.25	0.591	4.24	0.486	3.83
0.656	4.34	0.876	5.05	0.591	4.35
0.932	4.95	1.251	6.06	1.043	5.95
1.235	5.65	1.312	6.45	1.356	6.65
1.656	6.85	1.921	7.95	1.851	7.97
1.954	7.55	2.157	8.45	2.036	8.65
2.352	8.48	2.431	9.17	2.286	9.05
2.655	9.26	2.643	9.63	2.475	9.65
3.151	10.05	2.866	10.38	2.634	10.25

By fitting the curve, we can more intuitively understand the change law of the burst center distance and the height of the three wave points, as shown in Figure 6 below.

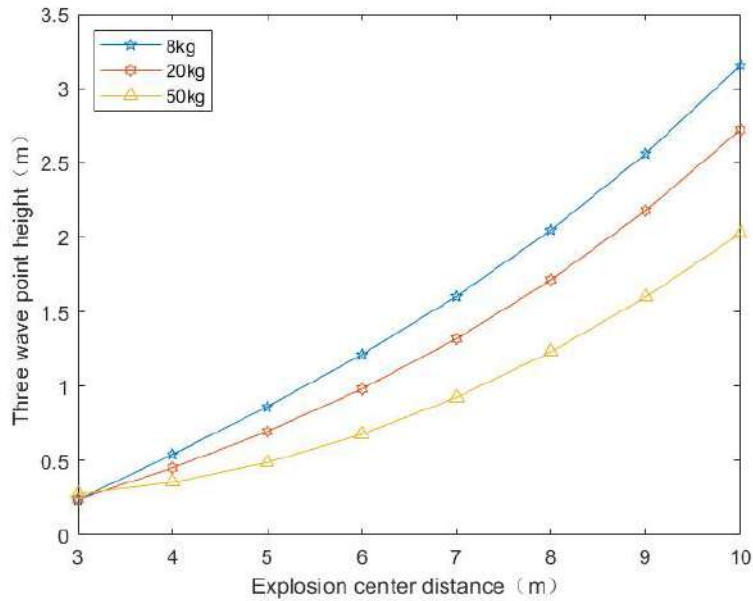

Fig. 6: The height of the three wave points varies with the burst center distance at different equivalents

It can be concluded from Figure 6 that the trajectory of the three-wave point shows an upward trend with the increase of the burst center distance. The height of the three-wave point has been increasing, and it roughly conforms to the law that the larger the equivalent is, the faster the height of the three-wave point increases. The greater the charge equivalent at the measuring point, the higher the height of the three wave points.

4.2 The three-wave point trajectory is affected by the explosive height of the grain

In order to study the influence of the three-wave point trajectory on the explosive height of the grain, the explosion height is respectively 1m, 2m, 3m, the TNT equivalent is 50kg, the length-to-diameter ratio is 1:1, and the detonation point is the central point of the grain. The three wave point heights at different burst center distances are shown in Table 5 for the simulation results.

Table 5: The height of the three wave points at each explosion center distance at different explosion heights

	Explosion center distance /m	Explosion height /m		
		1	2	3
Three wave point height /m	3	0.215	0.206	0.201
	3.5	0.458	0.354	0.312
	4	0.954	0.557	0.353
	4.5	1.153	0.655	0.425
	5	1.643	0.854	0.543
	5.5	1.957	0.958	0.557
	6	2.358	1.445	0.654
	6.5	2.643	1.623	0.826
	7	2.958	1.885	1.053
	7.5	3.254	2.254	1.254
	8	3.553	2.853	1.358
	8.5	4.056	3.355	1.557
	9	4.783	3.757	1.746
	9.5	5.345	4.343	2.054
10	6.133	4.856	2.476	

According to Table 5, the three-wave point height at each burst center distance at different explosion heights, the least square method is used for data fitting through MATLAB software, and

the three-wave point trajectory curve at different explosive heights of charge is obtained. As shown in Figure 7.

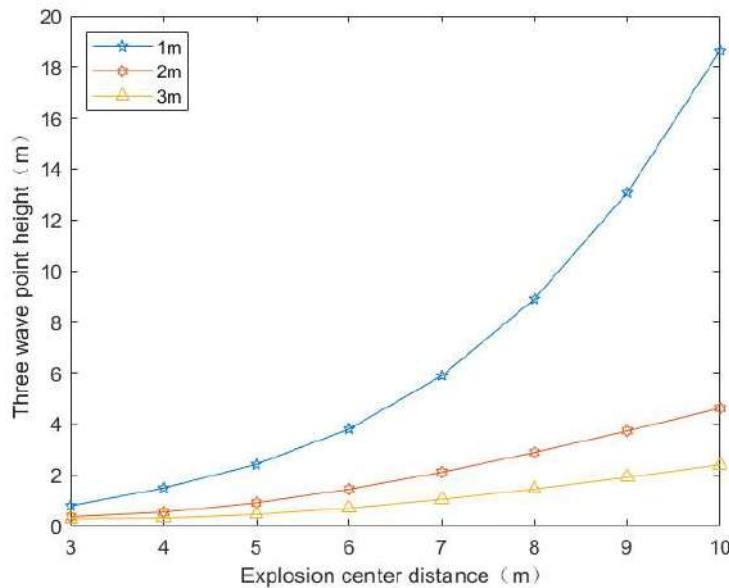

Figure 7: Comparison of three-wave point trajectory curves at different explosion heights

It can be seen from Fig. 7 that in the near field (burst distance <4.0m) the explosion height has no obvious influence on the three-wave point height trajectory, and in the midfield (burst distance 4.0~7.0m) and far field (burst distance >7.0 m) The height of the three wave points at the same measuring point decreases with the increase of the explosion height. The lower the explosion height, the faster the height trajectory of the three wave points rises.

#### 4.3 The three-wave point trajectory is affected by the position of the explosive point of the grain

The three-wave point trajectory is affected by the position of the detonation point of the grain. The detonation points are detonated at the center of the top of the grain, detonated at the center of the grain, and detonated at the center of the bottom of the grain. The TNT equivalent is 50kg, and the length-to-diameter ratio is 1:1. The explosion height is 2m for simulation analysis, and the three wave point heights at different explosion center distances can be obtained from the pressure cloud chart. Table 6 shows the simulation calculation results.

**Table 6:** The height of the three wave points of different initiation point positions at each burst center distance

	Explosion center distance/m	Detonation position		
		Top center point	Center point of grain	Bottom center point
	3	0.113	0.109	0.106
	3.5	0.161	0.154	0.134
Three wave point height /m	4	0.228	0.223	0.196
	4.5	0.356	0.307	0.263
	5	0.443	0.355	0.334
	5.5	0.558	0.457	0.427
	6	0.655	0.621	0.605
	6.5	0.836	0.826	0.795
	7	1.054	1.052	1.037
	7.5	1.353	1.352	1.312
	8	1.678	1.552	1.513
	8.5	2.245	1.935	1.835
	9	2.975	2.555	2.245
9.5	3.453	3.243	3.146	
	10	4.426	4.146	4.053

According to the three wave point heights at various burst center distances for different initiation point positions of TNT grains given in Table 6, the data fitting is performed by using the

least square method through MATLAB software, and the three wave point trajectories at different initiation point positions of TNT grains are obtained. curve. As shown in Figure 8.

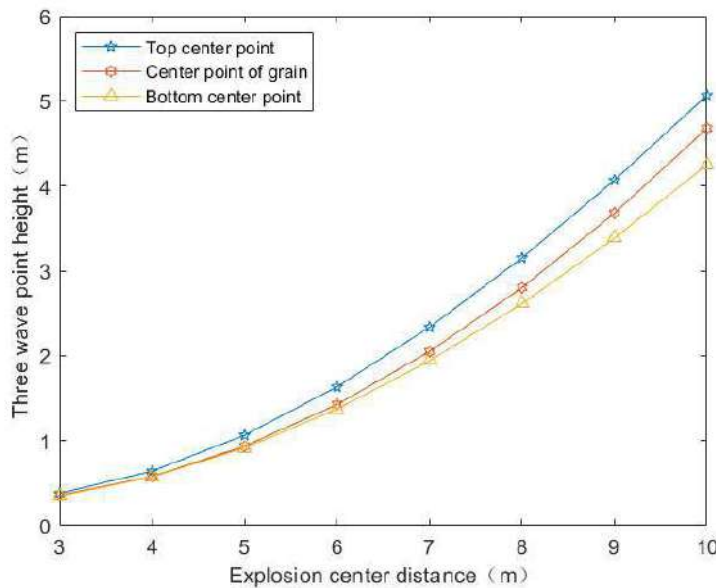

**Figure 8:** Comparison of three wave point height curves at different initiation points

It can be seen from Figure 8 that there is little difference in the three-wave height trajectories at different initiation point positions in the near field (burst distance <4.0m) and mid-field (burst center distance 4.0~7.0m), but in the far field (burst center distance > 7.0m) The influence of different initiating point positions on the height trajectory of the three wave points begins to appear. At this

time, the order of the height of the three wave points at the same measuring point is: the top center point, the grain center point, and the bottom center point. It shows that the higher the position of the initiation point, the higher the height of the three wave points at the same measuring point, and the faster the overall three wave point trajectory rises.

4.4 The three-wave point trajectory is affected by the size of the charge

The three-wave point trajectory is affected by the size of the charge. The charge size is 2:1, 1:1, 1:2. The TNT charge equivalent is 50kg, the explosion height is 1.5m, the explosive material is TNT, and

the detonation point The position is the top center point for simulation analysis, and the three wave point heights at different burst center distances can be obtained from the pressure cloud chart. Table 7 shows the simulation calculation results.

Table 7: Three wave point heights of different charge sizes at each burst distance

	Explosion center distance /m	Charge size		
		2:1	1:1	1:2
Three wave point height /m	3	0.221	0.312	0.353
	3.5	0.278	0.352	0.454
	4	0.314	0.567	0.767
	4.5	0.346	0.658	1.056
	5	0.436	0.855	1.254
	5.5	0.574	0.954	1.554
	6	0.726	1.478	1.733
	6.5	0.924	1.653	1.925
	7	1.157	1.868	2.052
	7.5	1.446	2.253	2.457
	8	1.832	2.857	3.258
	8.5	2.167	3.352	4.242
	9	2.352	3.756	4.955
	9.5	3.033	4.357	5.752
10	3.535	4.853	5.855	

According to the three-wave point heights at each burst point for different TNT charge sizes given in Table 7, the least squares method is used to fit the

data through MATLAB software, and the three-wave point trajectory curves for different TNT charge sizes are obtained. As shown in Figure 9:

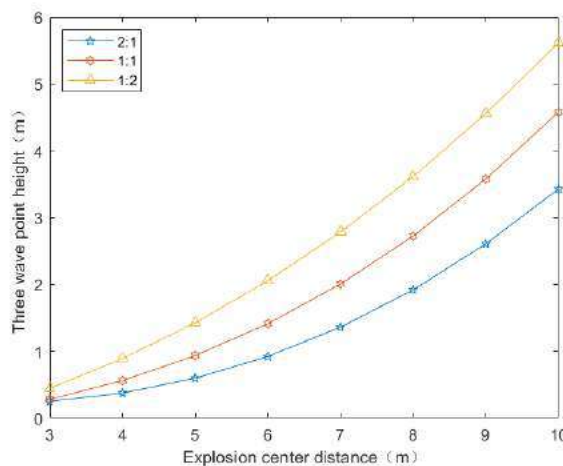

Figure 9: Comparison of three-wave point trajectory curves of different charge sizes

It can be seen from Figure 9 that, according to the size of the charge, the change of the three-wave point trajectory is also different. In the near field (burst distance <4.0m), the heights of the three-wave points with an aspect ratio of 1:1 and

2:1 are lower than the height trajectories of the three-wave points with an aspect ratio of 1:2. At the same measuring point in the midfield (burst distance 4.0~7.0m), the order of the height of the three wave points is length-diameter ratio 1:2>

length-diameter ratio 1:1> length-diameter ratio 2:1. In the far field (burst distance>7.0m), the three-wave point height sequence is the same as in the midfield, but the difference is more obvious. Overall, it shows that at the same measuring point, the larger the length-diameter ratio of the charge, the lower the height of the three wave points, and the more stable the overall trajectory.

*4.5 The trajectory of the three-wave point is affected by the explosive material*

The three-wave point trajectory is affected by the explosive material. The charge materials are TNT and HMX, the charge equivalent is 50kg, the explosion height is 2m, and the detonation point is the center of the charge for simulation analysis. Different burst centers can be obtained from the pressure cloud chart. The height of the three wave points at the distance, as shown in Table 8 is the simulation calculation result.

*Table 8:* Three wave point heights of different charge materials at each burst point

	Explosion center distance/m	Charge material	
		TNT	HMX
Three wave point height/m	3	0.221	0.354
	3.5	0.352	0.456
	4	0.524	0.557
	4.5	0.653	0.763
	5	0.852	0.968
	5.5	0.952	1.135
	6	1.495	1.535
	6.5	1.686	1.755
	7	1.742	1.864
	7.5	2.255	2.365
	8	2.454	2.653
	8.5	3.351	3.631
	9	3.753	3.842
	9.5	4.341	4.421
10	4.646	4.924	

According to the three wave point heights at each burst center distance for different charge materials given in Table 8, the least square method is used to fit the data through MATLAB

software, and the three wave point trajectory curves for different charge materials are obtained. As shown in Figure 10.

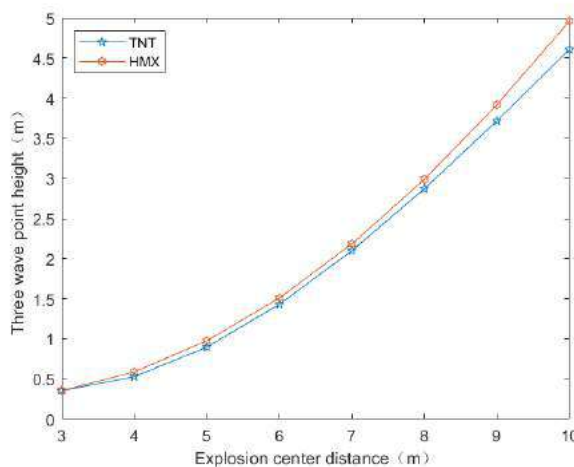

*Figure 10:* Comparison of three-wave point trajectory curves for different charging materials

It can be seen from Figure 10 that, according to the different charge materials, the changes of the three-wave point trajectory are also different. In the near field (burst distance <4.0m), the three wave point height trajectories of TNT and HMX are not much different. At the same measuring point in the midfield and far field, the order of the height of the three wave points is HMX>TNT, and the gap is more obvious than that in the near field.

#### 4.6 The three-wave point trajectory is affected by the reflective interface

The three-wave point trajectory is affected by the reflection interface, and SAND, STEEL, and

CONC-35 MPA are selected as the reflection interface. The TNT charge equivalent is 50kg, the explosion height is 2m, and the detonation point is the center point of the grain for simulation analysis. The pressure cloud chart can get the height of the three wave points at different burst center distances, as shown in Table 9 for the simulation calculation results.

Table 9: The height of the three wave points at each burst point at different reflection interfaces

	Explosion center distance/m	Reflection Interface		
		SAND	CONC-35MPA	STEEL
Three wave point height/m	3	0.221	0.214	0.203
	3.5	0.351	0.341	0.326
	4	0.555	0.513	0.485
	4.5	0.658	0.612	0.602

According to the three wave point heights at each burst center distance at different reflection interfaces given in Table 9, the data fitting is performed by using the least square method

through MATLAB software, and the three wave point trajectory curves at different reflection interfaces are obtained. As shown in Figure 11.

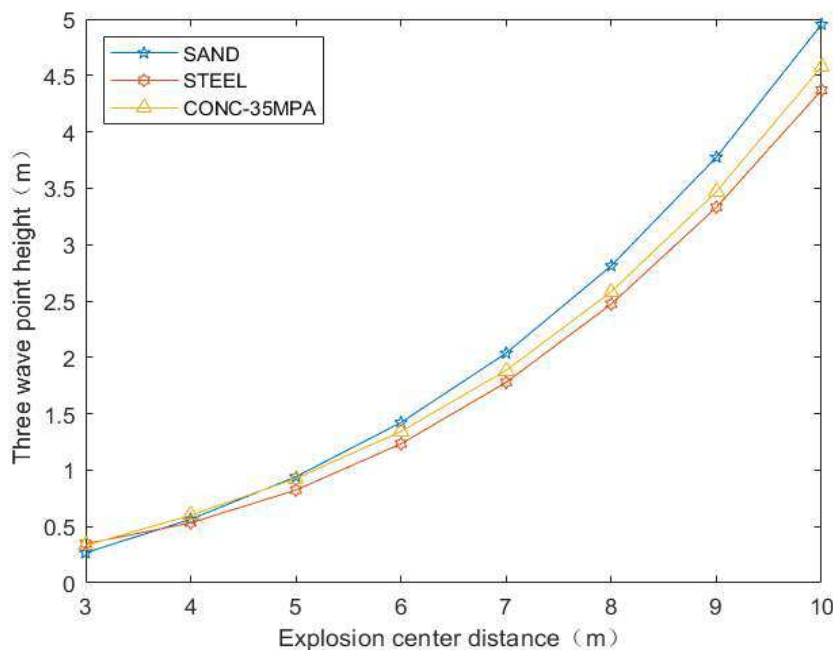

Figure 11: Comparison of three-wave point trajectory curves at different reflective interfaces

It can be seen from Figure 11 that the height of the three wave points at the same measuring point of the reflection interface of the sand material is the highest. The second is the concrete reflective interface, and the three-wave point trajectory is the lowest at the rigid interface. Because of the difference of the reflective interface, the ability to absorb the shock wave of the explosion is also different. Therefore, the different reflective interface has a great influence on the trajectory of the three wave points.

#### 4.7 The influence of sensor measuring point position on shock wave pressure test

When the finite element model was established, 15 Gaussian monitoring points were set up at

different heights and different burst center distances in order to study the change law of free field pressure at different positions with time. Figure 12 shows the pressure time history curve at each Gauss point when the TNT grain equivalent is 50kg, the length-to-diameter ratio of the grain is 1:1, the explosion height is 2m, and the detonation point is the center point of the grain.

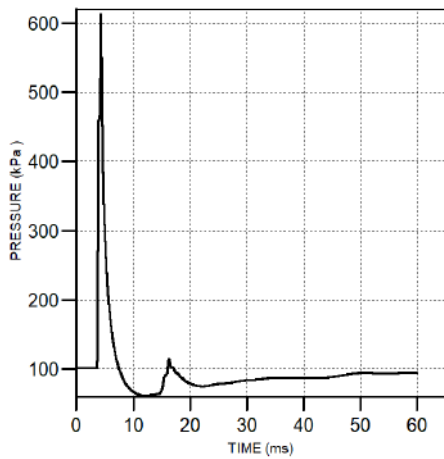

(a) 1m from the ground at 5m

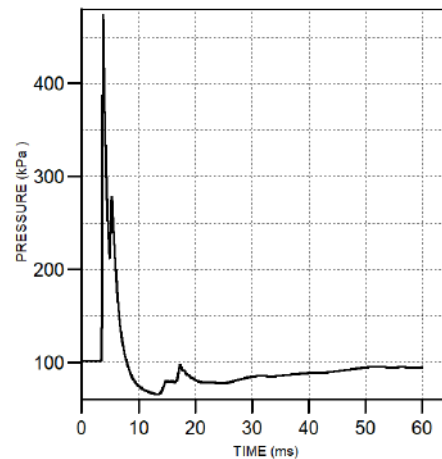

(b) 2m from the ground at 5m

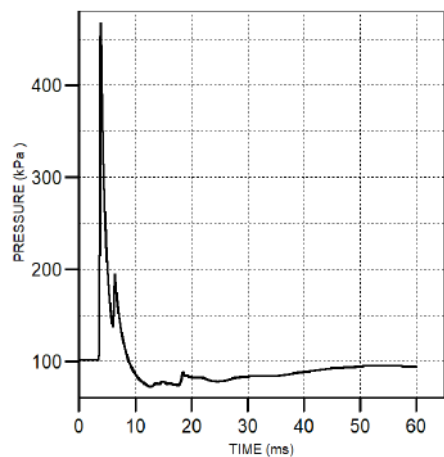

(c) 3m from the ground at 5m

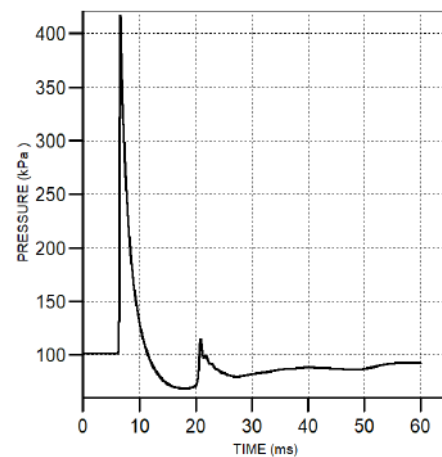

(d) 1m from the ground at 7m

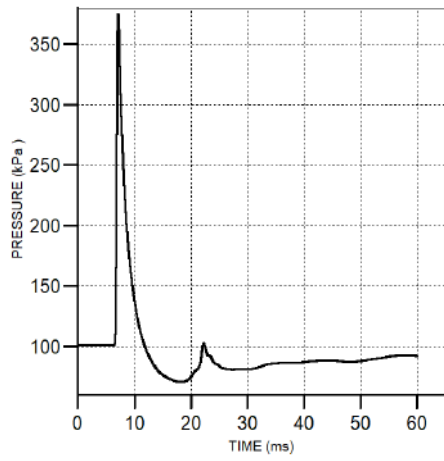

(e) 2m from the ground at 7m

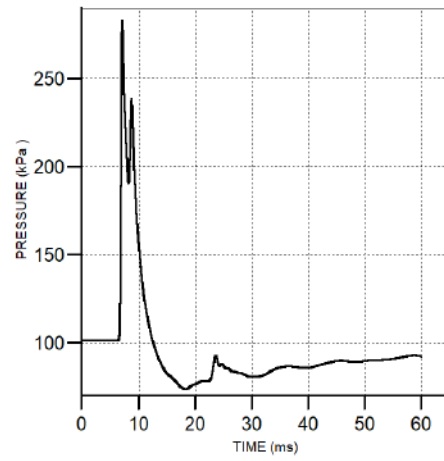

(f) 3m from the ground at 7m

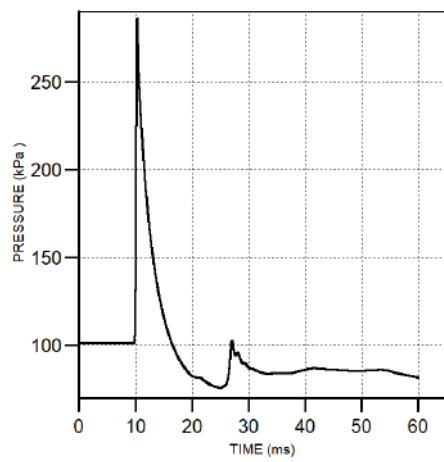

(g) 2m from the ground at 9m

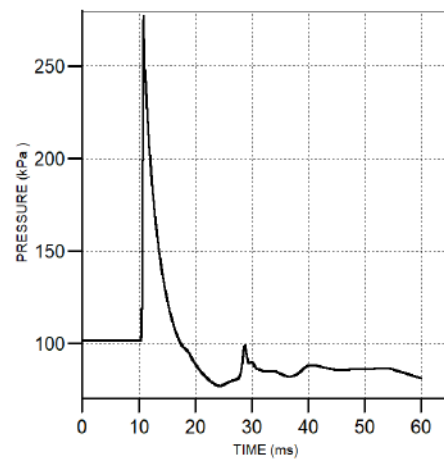

(h) 3m from the ground at 9m

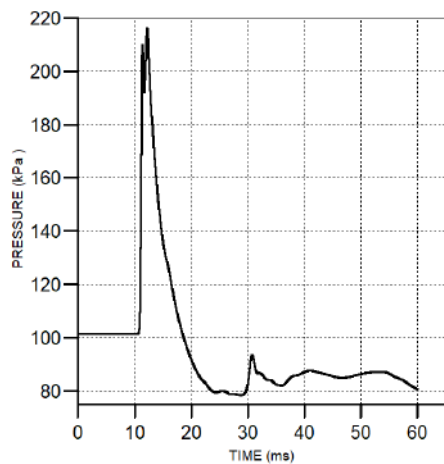

(i) 4m from the ground at 9m

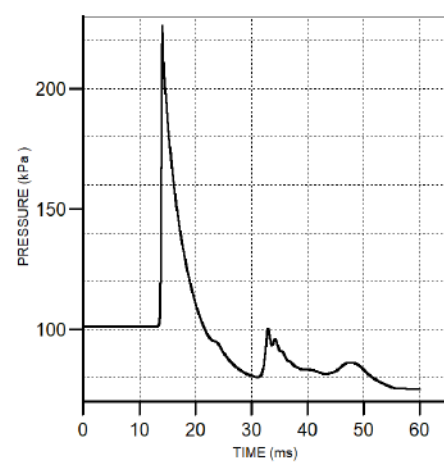

(j) 2m from the ground at 11m

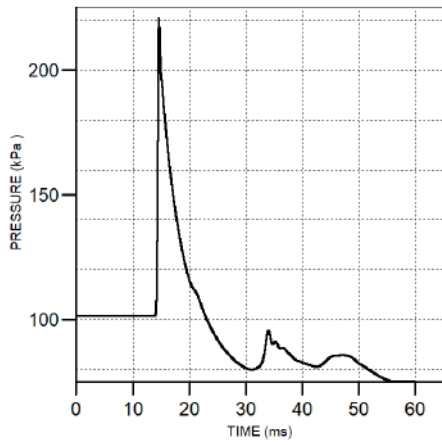

(k) 3m from the ground at 11m

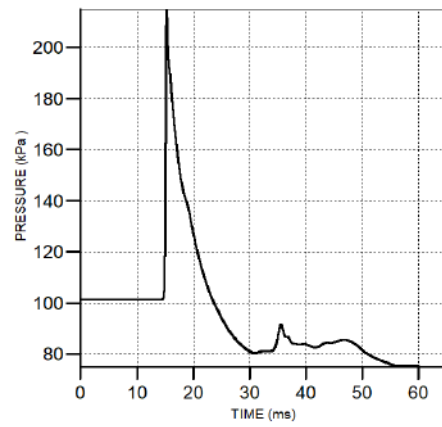

(l) 4m from the ground at 11m

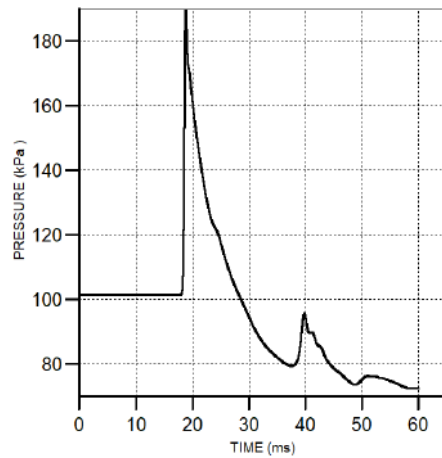

(m) 3m from the ground at 13m

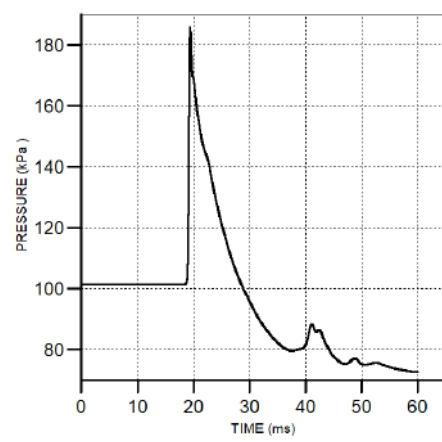

(n) 4m from the ground at 13m

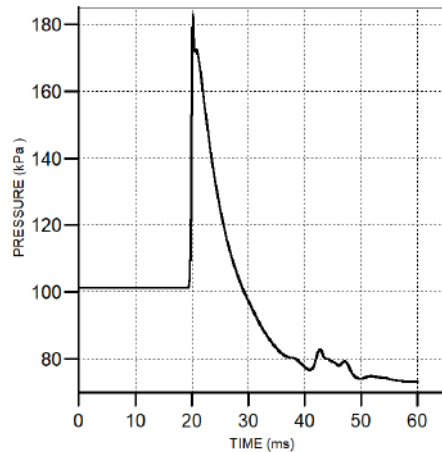

(o) 5m from the ground at 13m

*Figure 12:* Time history curve of free field pressure at different burst center distances

According to the free field pressure time history curve at different burst center distances in Fig. 12, Gauss points 1, 4, 5, 7, 8, 10, 11, 12, 13, 14, and 15 are below the three-wave point trajectory. At this time, the measured The Mach wave is a shock

wave synthesized by the incident wave and the reflected wave when the incident angle exceeds a certain limit angle, so at this time there is only one wave crest in the pressure-time history curve; Gauss points 2, 3, 6, 9 are at Above the three-wave

point trajectory, the incident wave is measured first, and then the ground reflection wave is measured. Therefore, there are two wave crests on the pressure time history curve. The first wave crest is the overpressure of the incident wave, and the latter is the overpressure of the reflected wave. According to the pressure time history curve measured at Gauss point 2 at a distance of 5m from the center of the explosion and a distance of 2m from the ground, it can be seen that the overpressure of the incident wave here is greater than the overpressure of the reflected wave. According to the pressure time history curve measured at Gauss point 9 at a distance of 9m from the center of the explosion and 4m from the ground, it can be seen that the overpressure of the incident wave here is smaller than the overpressure of the reflected wave. The reason for the two different situations is that the Gaussian point 2 is far away from the three-wave point trajectory. At this time, the wave front continues to spread and the reflected shock wave energy attenuates. At this time, the incident wave overpressure exceeds the reflected wave overpressure. The Gaussian point 9 is close to the three-wave point trajectory. At this time, the incident wave touches the ground to produce a complex reflected wave, and the reflected wave overpressure exceeds the incident wave overpressure.

In the experiment, if you want to measure the parameters of the incident wave more accurately, you need to set the sensor above the three-wave point.

## V. CONCLUSION

This paper uses AUTODYN finite element software to carry out numerical simulation, and calculates the influence of different factors on the three-wave point trajectory, which has guiding significance for the accurate measurement of various parameters in the explosion field in practice.

1. The height of the three-point trajectory of the shock wave formed by the explosion of the ammunition always increases with the increase of the distance between the center of the explosion.
2. The explosion height of the grain has a negative correlation with the height of the

three-wave point. When the charge equivalent is the same, the explosive height of the charge is changed. The higher the explosion height of the grain, the lower the height of the three-wave point and the slower the growth rate. The trajectory is smoother.

3. The change of the initiating point position in the midfield has little effect on the three-wave point trajectory. The higher the initiating point position in the far field, the faster the three-wave point trajectory increases.
4. The influence of the reflective interface on the height of the three-wave point is more complicated, and further research is needed.
5. Numerical simulation calculation has certain guiding significance for the layout of sensors.

## REFERENCES

1. Luo Xingbai, Zhang Yukui, A Course in Explosive Mechanics Theory[M]. Beijing: National Defense Industry Press, 2016:259-262. (in chinese).
2. Guo Wei, Yu Tongchang, Jin Penggang, Three-wave point measurement and experimental technology research [J]. Journal of Propellants, 2007(4):55-57+61. (in chinese).
3. Qiao Dengjiang, Air Blast Shock Wave (I) Basic Theory [J]. Explosion and Shock, 1985 (4):78-85. (in chinese).
4. Du Hongmian, Cao Xueyou, et al. Analysis and verification of air and ground shock wave characteristics of near-ground explosion [J]. Journal of Projectiles, Rockets and Guidance, 2014.34(4):65-68. (in chinese).
5. Duan Xiaoyu, Guo Xueshui, Nie Jianxin, et al. Numerical simulation of three wave point heights of RDX-based aluminum-containing explosives[J]. Chinese Journal of High Pressure Physics,2018(3):75-82. (in chinese).
6. Qu Yandong, Yang Shang, Li Siyu, et al. Numerical simulation of three wave points in the explosion field of TNT explosives[J]. Engineering Blasting,2019(1);1-6. (in chinese).
7. Wang Feng, Wang Bao, Dong Jing, et al. Study on the height of three wave points in the explosive field of penetration bomb[J]. Chinese Journal of Ordnance Equipment Engineering, 2018, 39(5):31-34. (in chinese)

8. Zhang Xuelun, Zhang Tuan, Wang Zhaoming. Numerical simulation based on the three-wave point of AUTODYN explosion field[J]. Chinese Journal of Ordnance Equipment Engineering, 2015, 36(3):17-19. (in chinese).
9. Zhang Ting, Explosive shock wave measurement technology (electrical measurement method) [M]. Beijing: National Defense Industry Press, 1984:7-15. (in chinese).
10. Song Pu, Yang Kai, Liang Anding, et al. The JWL equation of state of TNT explosives at home and abroad and the analysis of the difference in energy release[J]. Journal of Explosives, 2013, 36(2):42-45. (in chinese).
11. ZHANG X F, QIAO L. Detonation wave propagation in double-layer cylindrical high explosive charges[J]. Propellants Explosives Pyrotechnics, 2011, 36(3):210-218.



Scan to know paper details and  
author's profile

# Psychoanalytic View of Neurotic Forms of Love Object Choice

*Arjet Pervizi*

## INTRODUCTION

The way of building relationships and choosing a partner in life can not be something random between two people who decide to spend part of their lives together. Of course, many of our experiences in life lead us to certain choices.

Sigmund Freud, the founder of psychoanalysis, goes further when he says that partner selection is determined by the early relationship between child and parent. In his essay "On some neurotic mechanisms in jealousy, paranoia and homosexuality" (1922) Freud says that "these jealousies take root in the depths of the unconscious, taking back the earliest movements of infantile which arise and originate from the Oedipus complex" (p. 217) .. The roots for this are found in the triangle of the child-mother-father relationship and the phallic stage where the child shows the most pronounced closeness to the parent of the opposite sex (all this a necessary and indispensable process). The way of expressing love between parents and consequently the expression as triumphant in front of the child with the word "I took mom / dad" can affect that in adulthood the individual develops pathological behavior. Every behavior we explained in the above paragraph has its roots in early relationships.

*Keywords:* NA

*Classification:* DDC Code: 303.4840973 LCC Code: HN57

*Language:* English



LJP Copyright ID: 392955

Print ISSN: 2631-8474

Online ISSN: 2631-8482

London Journal of Engineering Research

Volume 22 | Issue 4 | Compilation 1.0



# Psychoanalytic View of Neurotic Forms of Love Object Choice

Arjet Pervizi

## INTRODUCTION

The way of building relationships and choosing a partner in life can not be something random between two people who decide to spend part of their lives together. Of course, many of our experiences in life lead us to certain choices.

Sigmund Freud, the founder of psychoanalysis, goes further when he says that partner selection is determined by the early relationship between child and parent. In his essay "On some neurotic mechanisms in jealousy, paranoia and homosexuality" (1922) Freud says that "these jealousies take root in the depths of the unconscious, taking back the earliest movements of infantile which arise and originate from the Oedipus complex" (p. 217). The roots for this are found in the triangle of the child-mother-father relationship and the phallic stage where the child shows the most pronounced closeness to the parent of the opposite sex (all this a necessary and indispensable process). The way of expressing love between parents and consequently the expression as triumphant in front of the child with the word "I took mom / dad" can affect that in adulthood the individual develops pathological behavior. Every behavior we explained in the above paragraph has its roots in early relationships.

Freud in his essay 'On Narcissism' (1922) talks about two ways of selecting the object of love:

1. *Choosing the object of love according to the narcissistic type:*

- a) A person who is like us.
- b) A person who is like us in the past.
- c) A person who represents an idealized image of himself in the future.

2. *Choosing the object of love according to the attachment:*

- a) A woman who cares for and nourishes her.
- b) A man who protects.

According to Freud, the narcissistic type of partner selection in life is more common in women and refers to the search for a partner, a fulfillment of self-love (p. 89, On Narcissism). According to Freud this explains why women constantly feel the need that their partners to express love to them or in other words, they desire to be loved more than they want to be. Based on this we can say that women are looking for a partner who is less narcissistic than them and is willing to invest from his libido, energy towards their object which is themselves, so they are attracted and look for a partner who pays attention and shows himself to her. The demand for representation in the presence of other individuals may have other unconscious roots related to the child-mother-father triangle. An unresolved issue in childhood due to love for the father and jealousy for the mother, may be the impetus for women to show pathological desire to look 'chosen'.

The selection of the object of love according to the form of attachment is based on the fixation on the figure of one of the parents during the infantile period of development. According to Freud in "Three Essays on Sexuality" (1922) this is more prevalent among men who try to seek the mother or part of the infantile experience lived in childhood in every woman they have in their life. By searching for the elements of the first infant relationship experienced in childhood, we understand the effort to fulfill the image of the mother through the elements of care, unconditional love and in certain moments the acceptance to be weak and small. However, the woman they have selected loses its importance when it starts to acquire the characteristics of a mother with elements such as restrictive, reprimanding, punishing and, most importantly

lack of love. Based on this, we can say that what men are looking for is to be forgiven by their partner despite their shortcomings. Thus they are in search of a kind of hidden instinctual desire to gain the partner's pride which is based on the infantile relationship with the mother and compliments with the desired attention of the mother in infancy. This also explains why men suffer criticism from their partner in a relationship. Such criticism can be perceived by the men as the end of the partner's love for him.

The relationship with the mother is essential for each of the sexes in the infantile stage of development. For women it is very important how love and rivalry is treated towards the object of love, which at an early age is the father. In the pre-oedipal stage, girls enjoy a deep connection with the mother, which serves as a form of internalization of the values, characteristics and image of the woman whom she will project later in life. The Oedipus phase is then characterized by a rivalry and hatred towards the figure of the mother as an attempt to defeat the competition and replace it with the love for the father. Parental behavior and treatment at this stage is very essential in building the character of the child. Typical behaviors which were mentioned above, such as: expression of love between the couple by making children jealous can cause a stagnation in the phallic stage precisely in the Electra complex. This can prompt individuals to project pathological behaviors driven by an unresolved element during this phase of life. We base this argument on what Freud says: "The pre-Oedipal connection phase is decisive for the future of the woman because during that period preparations are made for the acquisition of the characteristics with which she will fulfill her role in society" (p. 168, Introduction to Psychoanalysis). Just as the pre-Oedipal phase is important for the acquisition of feminine characteristics by the mother, so the post-Oedipus phase with hostility and rivalry towards the mother enjoys invaluable importance and serves as a prerequisite for a happy future marriage, elements which are preserved in it. But as Freud points out, "any relationship will experience moments when the enmity and rivalry carried by the infant relationship between mother and daughter is projected onto the spouse at a certain stage of life. For Freud, if this is

experienced in the beginning of the relationship, it is likely that the second part of the relationship will be happier. There is also a phase of calmness that is reached after the birth of the first child where the female learns to share the object of love and stops orienting everyone towards herself. By directing the attention towards the child, the female somehow gives up her narcissism. (p.168, Introduction to psychoanalysis). In cases when the first child is male, the female manages to feel a fulfillment after the replacement of what is called the conflict of the Oedipus complex in childhood. Now the woman has what she did not have as a child, a man has been born, whose roots stem from the desire to have a penis. This means a release of the relationship after the birth of the first child, especially if the gender of the child is male.

In her article "Narcissistic object choice in women" Annie Rich talks about the narcissistic choices of the object of love by women explains that: love (partner) ". Based on this I can say that women who have not had enough appreciation and attention during infantile intercourse may develop unhealthy forms of relationship build during adulthood. Annie Reich pointed out that women who approach partner selection from an extreme addiction attribute to him the characteristics of fantasy experienced during childhood. We can hypothesize that during childhood these individuals may have experienced an underestimation of the fact that they are female. They might have had a brother who was overestimated for the fact that he is male and has a penis or may have always felt incapable of receiving the object of love from the mother despite their efforts. There are women who during childhood have developed a way to get the attention of the object of love (in that case the father) through flattery, complaints, excessive femininity, etc. This form is also projected in adulthood as they choose the partner in life. Women who approach the choice of the object of love from an extreme addiction generally have a magnificent ideal such as ego or a weak ego, which both enjoy an exaggerated sense of self-criticism and inferiority. As a result they failed to master the object of love and inferiority which can only be fulfilled by an overrated partner. As a result of the inability to express her

aggressive feelings the woman sublimates them into masochistic behavior by easily accepting submission and even demanding it. In these cases the female manages to fulfill her inferiority by surrendering to a partner that dominates her. Separation from such an object can cause trauma up to conversion or psychotic disorders. To prevent this, we encounter cases in which women who persistently seek dominance to the point of excessive display of masculinity by their partner, either admit to be a second choice or admit to being betrayed. In these cases these women suffer less because the event that happened in the present is an known feeling to them. Praying for submission makes them feel valued and important in a relationship.

Before relating the elements of the above wording, it is necessary to clarify what is found to be healthy in attractions through partners in a relationship. Based on the Freudian premise: " In so many years of study I do not know what a woman wants", so that a woman does not know what she wants and at the same time wants many things she does not want. This is why the strongest instinctive weapon that a woman activates in the partner are two important elements: a) the masculine ability of being programmed to be complementary to the needs of the partner, b) promotes the display of masculine features through occasional outbursts aggressive. By activating the latter in the partner the female displays her ability to calm her partner through her femininity by showing it in a form the dominance, but not only, emphasizing once again her narcissism. It seems like a struggle for dominance (which the female just does not love anymore) and in the same time it is a magical spiral rooted within both sexes as complementary to each other as two incomplete halves separately. This is found to be a healthy form of relationship building between a couple.

The aspect that we will relate to is through what we have clarified so far . We will try to clarify the form of selecting a life partner as the object of love by women and the tendency to choose a category of men who have certain characteristics. In order to name the categories of men, we can refer to them with names such as: strong, those who feel nothing for you, thugs, gangsters, those who deal

with dirty work, etc. We will relate this to what Freud refers to as male motivators: power and sex. What I realised during my works such as therapeutic experience, numerous conversations in the auditorium, as well as many focus groups is that I find a pathological form of selection of the object of love by both sexes . Of course this was not discovered and developed now, but the current social conditions have affected its highlighting and influenced its formation.

The tendency to attract the category of men we labeled above comes as a form of acceptance or submission, i.e. a masochistic form of relationship is build by accepting and seeking submission. Annie Reich has emphasizes the selection of the object of love as an extreme form of addiction, as well as the overestimation of the object of love. We find women who select as an object of love the men we labeled above. Focusing on the elements of male power, perceived sexual ability, does not go beyond the pathological form of the selection of the object of love. Labeling this selection as absolutely as pathological were there is essentially only acceptance and submission., or as Annie Reich pointed out, masochistic. A stagnation in the phallic stage, an unquenchable desire for the male genital organ, a lost fight with the mother in infancy, a pronounced lack of attention to her needs, etc., foster and form the dependent character and pronounced tendency in the search for a male to overestimate it, as the only form of reliving its non-existence during the phallic phase. In this form, only by being ignored, by being oppressed do they feel worthwhile.

This can also be understood in other forms. We pointed out above that the female form of love is more pronounced than the narcissistic form were they portray themselves as an object of love and seek more love and attention that they are conscious about. The wrong tendency in choosing the object of love is observed in those relationships where women feel proud of their husband's power / sexual ability and promote this as a narcissistic form of saying that they are the ones who deserve it and also as a form of saying that they are the chosen ones and the others are "mom". This goes even further in the reason they give to the importance of male dominance over them in a relationship, overshadowing the

importance of communication and compromise as a healthy form of relationship development. The only form they can feel valuable is by appreciating dominance because in the early stage of development they have been important to the family only by acknowledging submission. I reiterate the search for validity in the manifestation of the partner's instinctive aggression, be it through "shouting, restraint, persistent search for jealousy on the part of the partner, the pathological desire for him to be desired by others but chosen to be you again, or even the manifestation of sexual aggression; they are nothing but pathological forms of experiencing a relationship, the roots of which we must persistently seek in what is experienced in the phallic stage of development.

The tendency to appear in front of an audience marked as more seductive women, as a form of challenging other women so that the position in the partner's arms is not threatened, is explained by the motive of the fear of substitution that the woman may have experienced during childhood age. The roots of this incorrect display of relationship building are again in the incorrect mother-daughter relationship and stagnation in the phallic stage. Precisely in what we call the Oedipus and Electra complex, were the child has constantly experienced the fear of losing position as father's favorite from mother's risk. The tendency to be seductive is just a form of expression. Other forms of expression are those mentioned above: flattery, excessive femininity, flattery, tendency to be dominant, complaints, attraction, etc. Each of these forms can be used as a form to attract a partner in life, but which all lies within the boundaries of the unhealthy form of choosing the object of love.

It is culturally unacceptable for women to act casually and based on what they feel they are doing. Given this very simple premise, and making the connection with the narcissistic form of the selection of the object of love by women, that one of the forms was the selection based on an idealized image of oneself in the future (above, point c), we note a tendency to pathologically select the object of love when its actions are generally instinctive and well thought, or to be more precise they feel attracted to those actions

which are a manifestations of id, which for the woman has been unacceptable during childhood because she was not a boy and did not enjoy the 'magnificent attribute' of having a penis.

To continue with a detailed analysis of how men choose the object of love we will start from what Freud wrote in his book in 1910 "Three essays on sexuality" where he spoke about the psychic impulses that push a neurotic man to select the object of his love.

Freud points out that such psychic impulses are often encountered even in persons with normal mental health.

#### *Rivalry: The existence of an injured party*

A man would never choose as a partner a woman who is free and has no interest in him, but only the one through whom he would realize the right of domination as a husband.

Some relationships can start from scratch, where no one expects something to happen between two individuals. This is due to some impulses which are completely unconscious. There is a category of men whom Freud described as neurotic in choosing the object of love. They may begin to feel attracted to a woman for whom they had no previous feelings, just because someone else is interested in her. This falls into the category of "rivalry or existence of an injured party". The approach of building relationships by men is found through observation and therapeutic works of the unconscious. Also due to the unconscious impulse of rivalry we see men who show a pronounced need for the partner to be attractive as a condition to build the relationship, so that when others talk about it or see it constantly, as a form of showing off in persistently dominating other men. An unresolved issue in the Oedipus complex and a strong childhood feeling that the child experienced while growing up is that the mother belongs to someone else (the father) and that he finds it impossible to receive her love, leads to the formation of this neurosis in men. In this way, the selection of the object of love based on rivalry, complements in men the feeling of the injured third party.

*Jealousy:* A woman who is rumored to be: "A woman who is chaste and whose reputation is

pure is never an attraction to be able to raise her to the status of an object of love", but only a woman whose fidelity and credibility is open to doubt.

Improper explanations for the nature of sexual intercourse between parents or open intimate relations between partners in the eyes of their children can promote the formation of this neurosis which appears in adulthood. For children and also for every adult, the mother is a symbol of purity, honesty and chastity. Children facing experiences that can damage this image of the mother in their mind, for example through the thought: "my mother also has sex like everyone else", or "kisses, explicit sexual hugs", can lead to formation of this neurosis. Expressions of love between partners should be oriented towards the values of respect, courtesy, care, etc. rather than clear manifestations of actions of a sexual nature but without neglecting the latter. The appearance of sexual acts in the eyes of children is important in conveying the message to male children to build the idea that the mother plays the role of the father and thus activates the Oedipus complex, during the pre-Oedipal stage were the male child will assimilate the values of the father in order to be the mother's favorite, and at this point arises the need to display caring and respectful behaviors in order that the child acquires these values. The Oedipal stage were the child displays feelings of rivalry with the father helps him project love to another woman outside his circle, which coincides with the latent and then genital stage where the first pleasures begin.

#### *Uninterrupted compulsive repetition:*

In these love relationships the character of a man is formed, which in a way adapts to any occasion of falling in love. Such relations are repeated with the same qualities in different stories as copies of each other.

Cultural approaches with a very strong deterrent and moralistic tendency towards the relationship between the male child and the mother when he shows feelings of affection, love or physical closeness to the mother influences the formation of this neurosis. Numerous expressions such as "leave your mother because you are already an adult; enough to kiss the mother; how the boy sits

on mom's lap" etc., can influence the male child to repress the instinctive desire which later in life is projected in love directed only in an emotional and affective aspect. These men in the genital stage of development feel that they can form relationships with any woman which offers emotional affection. The roots of this lies in the fixation created on the figure of the mother. Generally, these men tend to choose partners who are in a lower status than them, which would ensure the affection and love of the partner.

#### *Salvation fantasies:*

The man is convinced that the woman needs him and believes that without him she would lose all moral control and quickly fall into a miserable level.

It often happens to see a man mature in life and profession falling in love with a suffering woman whose social status may be put at risk. The man feels a strong need that the woman needs him and if he doesn't save her she will fall into a miserable condition. In most cases, these men do not manage to fall in love or feel attracted to women who appear self-confident or who may have a built-in career, which conveys the lack of need to save her.

During the phallic stage of development in the early infant relationship, rather than losing the war in trying to win the love of the parent of the opposite sex, for a child whether girl or boy, it leaves irreversible traces (as early as the next day), may have pathological consequences, if he / she (child) mistakenly perceives that \*same-sex parent is not worth fighting\* and directs to him / her feelings of pity, pain, or care. The primary conflict with the same sex is essential in the acquisition of values, norms and characteristics by the child. This serves as a mechanism to appear "liked" in the eyes of the parent of the opposite sex. These likes that in the genital stage of development, are projected externally on the partners we choose in life!

"I would not have wanted anything more in life than protecting my father," says Freud. For the man a weak father who is not worth fighting to get the mother's love is the main impetus in the formation of this neurosis in men. This category sees the father as powerless to please the mother

and consequently does not fight for her. By not activating rivalry for the father in the struggle for the mother's love, the male child is not encouraged to take from the father his values and characteristics in order to be the mother's favorite in her eyes. Thus during the infantile stage of development the male child directs towards the mother the feelings of fantasy and salvation, which he must bring to the mother god since the father is not enough. He must save her from that condition otherwise the mother will be with a partner who is worthless, weak and not masculine enough, etc. In these cases we can have reports where the father may be completely indifferent to the partner, not present, shows lack of love, protection and caring skills towards the partner.

At the end of this part, which is absolutely not exhausted, I can say that whether consciously or unconsciously there is a tendency to encourage Albanian youth to act instinctively, as a form of expression of complete freedom, which as we tried to clarify it often leads us to various pathologies that we do not always have the willingness and comfort to understand.

What I think is that people are more easily managed through instinct and chaos rather than through order and those who may have certain interests in influencing the culture of a country have it very clear. To destroy a superego, one must give unconditional freedom to the id, motivating what it is portrayed as something publicly accepted promoting it in the media thus making it socially acceptable. Wrongly, although nothing goes wrong, the manifestations of the id have now turned into a new superego, and those impulses which the id conveyed hitherto and caused the necessary conflict for the existence of the ego, are no more, and the id must produce other desires, which will certainly be more pathological than the previous ones.

To put it more into practice and to make it more tangible, what until yesterday was socially unacceptable and was part of the morals of the superego, today is considered something socially desirable and sought after by most young people forming thus a new social "morality" for the

generation in which we live. Once this is internalized, the id will produce a gain and continuously new impulses which have the sole purpose of achieving momentary satisfaction, which is achieved but does not provide stability and guarantee, ie does not fulfill. So the id will continuously produce dark pulses because according to the pleasure principle the impulses that the id transmits the moment they are met widen and deepen the threshold so the next time the id transmits a pulse, it will have to be deeper and greater than the former in order to feel the momentary satisfaction. This becomes more difficult in the moment we replace the superego, cultural, religious, legal morals, etc.; with elements that id himself has dictated to us.

## REFERENCA

1. Freud Sigmund, "Three Essays on Sexuality", Fan Noli, Tirana, 1998.
2. Freud Sigmund, "On Narcissism, an Introduction", The Hogarth Press, London, 1975.
3. Reich Annie, "Narcissistic object choice in women", Journal of the American Psychoanalytic Association 1: 22-44, 1953.
4. Freud Sigmund, "New introductory lectures on psychoanalysis", Penguin Books, Harmondsworth, 1973